

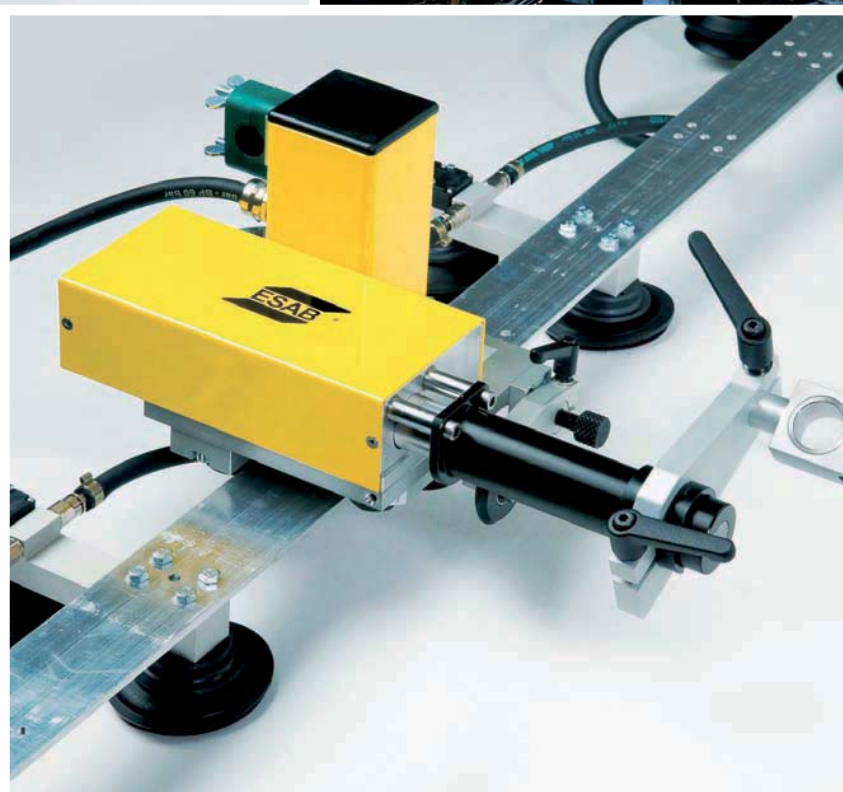

Product catalogue 5th edition

Standard Equipment and Welding Automation

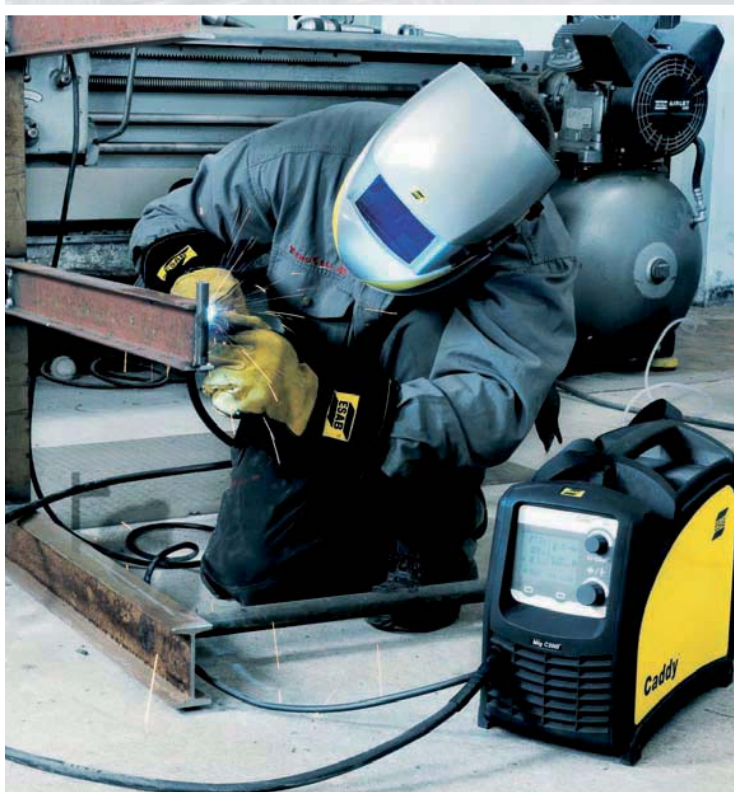

Contents

Welding equipment

MMA equipment	3
Engine driven welders	6
TIG equipment	10
MIG/MAG equipment	20
Ancillary equipment	48
Manual plasma cutting equipment	58

Welding automation

Orbital TIG welding	64
Mechanisation equipment	76
Tractor automats	80
Welding heads, power sources	86
Wear parts	90
Carriers and gantries	92
Components and modules	94
Flux equipment	96
Column and boom	98
Handling equipment	102
Engineering	104

MMA equipment

Inverters



Caddy® Arc 151i, A31

Compact and portable inverter for MMA and scratch start TIG welding.

- Durable and impact resistant design with OKC 50 cable connectors.
- Easy to operate. Only current setting needed.
- Automatic hot-start and arc force.
- Can operate with extra long mains cables, over 100 m, thanks to the built in PFC circuit.
- Welds most electrodes from Ø 1.6 - 3.2 mm and some 4 mm electrodes.
- IP 23 – designed for outdoor use making it safe on all work sites

Delivery includes

3 m mains cable with plug, 3 m MMA welding and return cable kit ("screw" type holder).

**Caddy® Arc
151i, A31**

Mains supply, V/Hz	230/1 50/60
Fuse, slow, A	16
Mains cable, Ø mm ²	3x2.5
Max output at 25% duty cycle, A	150/26
Max output at 60% duty cycle, A	100/24
Max output at 100% duty cycle, A	90/23.6
Setting range, A	8 - 150
Open circuit voltage (VDR off/on), V	58-72/NA
Power factor at max current	0.99
Weight, kg	7.9

Ordering information

Caddy® Arc 151i, A31	0460 445 881
Accessories:	
Shoulder strap	0460 265 003
Caddy® bag on wheels	Y000 512 880



Caddy® Arc 151i/201i, A33

Compact and portable inverter for MMA and TIG welding with electronically controlled LiveTig™ start.

- Durable and impact resistant design with OKC 50 cable connectors.
- Easy to operate. Digital display for settings.
- Adjustable hot-start and arc force for accurate weld setting.
- ArcPlus™ II regulator for better welding characteristics. Higher weld quality with less after treatment.
- Two memories for storing of settings.
- Remote control possibility
- Can operate with extra long mains cables, over 100 m.
- Caddy® Arc 151i welds most electrodes from Ø 1.6 - 3.2 mm and some 4 mm electrodes.
- Caddy® Arc 201i welds most electrodes from Ø 1.6 - 4 mm.
- IP 23 – designed for outdoor use making it safe on all work-sites.

Delivery includes

3 m mains cable with plug, 3 m MMA welding and return cable kit ("screw" type holder).

**Caddy® Arc
151i, A33**

**Caddy® Arc
201i, A33**

	Caddy® Arc 151i, A33	Caddy® Arc 201i, A33
Mains supply, V/Hz	230/1 50/60	230/1 50/60
Fuse, slow, A	16	16
Mains cable, Ø mm ²	3x2.5	3x2.5
Max output at 25% duty cycle, A	150/26 (MMA), 150/16 (TIG)	170/26.8 (MMA), 220/18.8 (TIG)
Max output at 60% duty cycle, A	100/24 (MMA), 120/14.8 (TIG)	130/25.2 (MMA), 150/16.0 (TIG)
Max output at 100% duty cycle, A	90/23.6 (MMA), 110/14.4 (TIG)	110/24.4 (MMA), 110/14.4 (TIG)
Current range TIG DC, A	3 - 150	3 - 220
Current range MMA DC, A	4 - 150	4 - 170
Open circuit voltage (VDR off/on), V	72/NA	72/NA
Power factor at max current	0.99	0.99
Weight, kg	7.9	8.3

Ordering information

Caddy® Arc 151i, A33	0460 445 883
Caddy® Arc 201i, A33	0460 445 884
Accessories:	
Shoulder strap	0460 265 003
Caddy® bag on wheels	Y000 512 880

MMA equipment

Inverters



Caddy® Arc 251i, A32/A34

Compact and portable three phase inverter for MMA and TIG welding with electronically controlled LiveTig™ start.

- Durable and impact resistant design with OKC 50 cable connectors.
- Easy to operate. Digital display for settings.
- ArcPlus™ II regulator for better welding characteristics. Higher weld quality with less after treatment.
- Adjustable hot-start and arc force for accurate weld setting (A34).
- Two memories for storing of settings (A34).
- Electrode type selector for optimised performance (A34)
- Remote control possibility
- Can operate with extra long mains cables, over 100 m, thanks to the built in PFC circuit.
- Welds all electrodes from Ø 1.6 - 5 mm; basic, rutile and cellulosic.
- IP 23 – designed for outdoor use making it safe on all work sites

Delivery includes

3 m of mains cable with plug, 3 m MMA welding and return cable kit ("screw" type holder).

Caddy® Arc 251i

Mains supply, V/Hz	400/3 50/60
Fuse, slow, A	10
Mains cable, Ø mm ²	4x1.5
Max output at 30% duty cycle, A	250/30
Max output at 60% duty cycle, A	190/27.6
Max output at 100% duty cycle, A	150/26
Current range TIG DC, A	3 - 250
Current range MMA DC, A	4 - 250
Open circuit voltage (VDR off/on), V	62/<35
Power factor at max current	0.94
Weight, kg	10.5

Ordering information

Caddy® Arc 251i, A32	0460 300 880
Caddy® Arc 251i, A34	0460 300 881
Accessories:	
Shoulder strap	0460 265 003
Caddy® bag on wheels	Y000 512 880



Origo™ Arc 4001i, A22/A24

Origo™ Arc 4001i is an ideal partner when it comes to efficient production indoor or outdoor, installation on site or all type of repair & maintenance welding.

The power source is compact and sturdy with a chassis made of galvanized steel. This is a robust material that withstands rough treatment.

You can choose between two control panels, A22/A24, depending upon your requirements and demands.

Delivery includes

5 m mains cable incl plug

Origo™ Arc 4001i, A22/A24

Mains supply, V/Hz	400, 3~ 50/60
Fuse, slow, A	20
Mains cable, Ø mm ²	4x4
Max output at 35% duty cycle, A	400 / 36
Max output at 60% duty cycle, A	320 / 32.8
Max output at 100% duty cycle, A	250 / 30
Current range MIG, A	20 - 400
Current range MMA DC, A	16 - 400
Current range TIG DC, A	4 - 400
Open circuit voltage (VDR off/on), V	58/<35
Power factor at max current	0.89
Weight, kg	40

Ordering information

Origo™ Arc 4001i, A22	0460 455 880
Origo™ Arc 4001i, A24	0460 455 881
Accessories:	
Trolley 2-wheel	0460 564 880
Feeder platform, Trolley 2-wheel	0460 815 880
Protection frame	0460 459 880

MMA equipment

Rectifiers



Origo™ Arc 250/300/400

- Low investment cost per Ampere
- No electronics – an advantage for remote operations
- Multi-voltage version available
- Approved according to European standards – CE-marked
- Supplies direct current – welds most materials
- Made to be used with Citoflex cellulosic electrodes
- Designed for use in damp and confined areas – S marked

Delivery includes

Wheels, handle and a 3 m mains cable

	Origo™ Arc 250	Origo™ Arc 300	Origo™ Arc 400
Mains supply, V/Hz	400/50-60	400/50-60	400/50-60
Fuse, slow, A	25	25	35
Setting range, A	50-250	55-300	65-400
Open circuit voltage, V	65-75	65-75	70-80
Weight, kg	98	105	158

Ordering information

Origo™ Arc 250	0700 160 880
Origo™ Arc 250, 230/400/500/550 V, 50/60 Hz	0700 160 883
Origo™ Arc 300	0700 160 881
Origo™ Arc 300, 230/400/500/550 V, 50/60 Hz	0700 160 884
Origo™ Arc 400	0700 160 882
Origo™ Arc 400, 230/400/500/550 V, 50/60 Hz	0700 160 885



Origo™ Arc 410c/650c/810c

The Origo™ Arc 410c, 650c and 810c are sturdy and robust switching converter (chopper) power sources intended for manual heavy duty MMA welding with coated electrodes, TIG welding and Air Carbon Arc Gouging.

Well proven technology with a high level of reliability, outstanding weld performance, a strong metal housing and large wheels for ease of handling, make this range of machines ideal for use in the toughest of industrial environments.

	Origo™ Arc 410c	Origo™ Arc 650c	Origo™ Arc 810c
Mains supply, V/Hz	230/400-415/500 V, 3~50 Hz, 230/440-460/550 V, 3~60 Hz	230/400-415/500 V, 3~50 Hz, 230/440-460/550 V, 3~60 Hz	230/400-415/500 V, 3~50 Hz, 230/440-460/550 V, 3~60 Hz
Max output at 35% duty cycle, A	400 A / 36V	650 A / 44V	800 A / 44V
Max output at 60% duty cycle, A	310 A / 33V	490 A / 40V	630 A / 44V
Max output at 100% duty cycle, A	240 A / 30V	400 A / 36V	500 A / 40V
Setting range, A	20A/20V - 400 A/36V	20A/20V - 650 A / 44V	20A/20V - 800 A / 44V
Open circuit voltage, V	56	56	56
Weight, kg	157	223	245

Ordering information

Origo™ Arc 410c, A12	0349 310 650
Origo™ Arc 410c, A11	0349 311 200
Origo™ Arc 410c, A12 offshore	0349 311 480
Origo™ Arc 410c, A12 stationary	0349 311 490
Origo™ Arc 650c, A12	0349 311 210
Origo™ Arc 650c, A12 offshore	0349 311 500
Origo™ Arc 650c, A12 stationary	0349 311 510
Origo™ Arc 810c, A12 offshore	0349 311 430

Engine driven welders

Engine driven welders



KHM 190 HS – petrol

A combined engine-driven welding unit and 1ph 230V and 3ph 400V power-generating unit. It allows you to work in environments in which it is difficult or impossible to connect to the mains supply.

Compact and portable, the KHM 190 HS gives you a combination of 190A strong, high-quality DC welding and up to 6kVA of electric power. All in the same unit. The perfect partner for quick repair or assembly work.

The KHM 190 HS has a Honda petrol engine with pull start. Other features include: oil alert engine protection, thermal load and residual current device.

Delivery includes

Wrap-around protection frame.

KHM 190 HS

Setting range, A	20-100, 90-190
Max output at 35% duty cycle, A	190
Max output at 60% duty cycle, A	160
Max output at 100% duty cycle, A	120
Open circuit voltage, V	98
AC Power generation:	
Single Phase, Volts/kVA/Hz	230/5/50
Three Phase, Volts/kVA/Hz	400/6/50
Engine type	Honda GX 390
Sound level, dB(A)/LWA	73/98
Power, kW/rpm	8.4/3000
Weight, kg	115

Ordering information

KHM 190 HS	0794 000 880
Trolley	0794 009 880
Earthing kit	0794 017 880
Welding cable	0700 006 884
Return cable	0700 006 885



KHM 190 YS – diesel

This unit has the same performance as the KHM 190 HS, but it has a diesel engine.

A diesel engine is sometimes preferred as it has a much higher flashpoint than petrol and is thereby much safer in terms of combustibility. Diesel can also be stored a couple of years and still be usable.

Diesel engines consume less fuel, at a lower cost for the same power. Diesel engines are also known to have a longer service life. The disadvantage is the higher weight.

The KHM 190 YS has a Yanmar diesel engine with battery and electrical start. Other features include: battery charge indicator, oil alert engine protection, thermal load and residual current device.

Delivery includes

Wrap-around protection frame and battery.

KHM 190 YS

Setting range, A	20-100, 90-190
Max output at 35% duty cycle, A	190
Max output at 60% duty cycle, A	160
Max output at 100% duty cycle, A	120
Open circuit voltage, V	98
AC Power generation:	
Single Phase, Volts/kVA/Hz	230/5/50
Three Phase, Volts/kVA/Hz	400/6/50
Engine type	Yanmar L 100 AE
Sound level, dB(A)/LWA	73/100
Power, kW/rpm	6.5/3000
Weight, kg	156

Ordering information

KHM 190 YS	0794 000 882
Trolley	0794 010 880
Earthing kit	0794 017 880
Welding cable	0700 006 884
Return cable	0700 006 885

Engine driven welders

Engine driven welders



KHM 351 YS

Engine driven welding unit made to weld with coated electrodes. For professional heavy duty repair, maintenance and assembly work.

The wide working range makes it possible to perform a large variety of work in environments where it is difficult, costly or impossible to connect to the mains supply. This thyristor controlled compact and transportable unit gives you a combination of strong, high quality DC current for coated electrode welding (MMA). The same unit also supplies up to 12kVA electric power depending on welding current used.

Delivery includes

Machine complete with engine oil, coolant and charged battery (maintenance free).

KHM 351 YS

Setting range, A	20-350
Max output at 35% duty cycle, A	350
Max output at 60% duty cycle, A	320
Max output at 100% duty cycle, A	270
Open circuit voltage, V	65
AC Power generation:	
Single Phase, Volts/kVA/A/Hz	230/7/30.4/50
Three Phase, Volts/kVA/A/Hz	400/12/17.3/50
Engine type	Yanmar 3 TNV 76
Sound level, dB(A)/LWA	72/97
Power, kW/rpm	16.5 (22.3) / 3000
Weight, kg	535

Ordering information

KHM 351 YS, 50 HZ	0794 019 880
KHM 351 YS, 50 Hz, with spark arrestor	0794 019 881
KHM 351 YS, 50 Hz, with polarity change	0794 019 882
KHM 351 YS, 50 Hz, with spark arrestor and polarity change	0794 019 883
Accessories:	
Remote control PHG1B	0794 008 882
Remote control PHG1B-PL (for polarity change versions)	0794 008 885
2 wheel site tow	0794 014 880
Earth spike	0794 017 880



KHM 405 YS

Digitally controlled engine driven welding unit made to weld MMA, TIG or MIG/MAG. For professional heavy duty repair, maintenance and assembly work.

The wide working range makes it possible to perform a large variety of work in environments where it is difficult, costly or impossible to connect to the mains supply. This chopper controlled compact and transportable unit gives you a combination of strong, high quality DC current for excellent MMA, TIG or MIG/MAG welding. The same unit also supplies up to 12kVA electric power depending on welding current used.

Delivery includes

Machine complete with engine oil, coolant and charged battery (maintenance free).

KHM 405 YS

Setting range, A	10-400
Max output at 35% duty cycle, A	400 (MMA)
Max output at 60% duty cycle, A	350
Max output at 100% duty cycle, A	300
Open circuit voltage, V	65
AC Power generation:	
Single Phase, Volts/kVA/A/Hz	230/7/30.4/50
Three Phase, Volts/kVA/A/Hz	400/12/17.3/50
Engine type	Yanmar 3 TNV 76
Sound level, dB(A)/LWA	72/97
Power, kW/rpm	16.5 (22.3)/3000
Weight, kg	535

Ordering information

KHM 405 YS, 50 Hz	0794 020 880
KHM 405 YS, 50 Hz, with spark arrestor	0794 020 881
KHM 405 YS, 50 Hz, with polarity change	0794 020 882
KHM 405 YS, 50 Hz, with spark arrestor and polarity change	0794 020 883
Accessories:	
Connector kit for Origo™ Feed, M13	0740 741 881
Remote control PHG1B	0794 008 882
Remote control PHG1B-PL (for polarity change versions)	0794 008 885
2 wheel site tow	0794 014 880
Earth spike	0794 017 880

Engine driven welders

Engine driven welders



KHM 525 PS

Digitally controlled engine driven welding/electric power unit made to weld MMA, TIG or MIG/MAG. For the toughest, professional, heavy-duty repair, maintenance and assembly work. For the toughest environments needing high capacity. The wide working range together with the possibility for carbon arc gouging makes it possible to perform a large variety of work in environments where it is difficult or impossible to connect to the mains supply. KHM 525 PS is equipped with a powerful and efficient water-cooled Perkins diesel engine with battery and electric start.

Delivery includes

Machine complete with engine oil, coolant and charged battery (maintenance free).

KHM 525 PS

Setting range, A	10-500
Max output at 35% duty cycle, A	500 (MMA and TIG)
Max output at 60% duty cycle, A	450
Max output at 100% duty cycle, A	400
Open circuit voltage, V	62
AC Power generation:	
Three Phase kVA/V/A	16/400/23.1
Single Phase kVA/V/A	12/230/52.2
Engine type	Perkins 404 C-22G
Sound level, dB(A)/LWA	71/96
Power, kW/rpm	20.3 (27.6) / 1500
Weight, kg	750

Ordering information

KHM 525 PS, 50 Hz	0794 021 880
KHM 525 PS, 50 Hz, with spark arrestor	0794 021 881
KHM 525 PS, 50 Hz, with polarity change	0794 021 882
KHM 525 PS, 50 Hz, with spark arrestor and polarity change	0794 021 883
Accessories:	
2 wheel site tow	0794 012 880
PHG1B, remote control 20 m	0794 008 882
Remote control PHG1B-PL (for polarity change versions)	0794 008 885
Earth spike	0794 017 880
Connector kit for Origo™ Feed, M13	0740 741 881



KHM 595 PS

Engine driven welding/electric power units for the toughest, professional, heavy-duty repair, maintenance and assembly work. For the toughest environments needing high capacity. The wide working range together with the possibility for carbon arc gouging makes it possible to perform a large variety of work in environments where it is difficult or impossible to connect to the mains supply. KHM 595 PS is equipped with a powerful and efficient, water-cooled Perkins diesel engine with battery and electric start.

KHM 595 is a full multiprocess equipment which can be used in all processes; MMA, TIG and MIG/MAG. The equipment also has the possibility to give up to 30 kVA electrical power.

Delivery includes

Machine complete with engine oil, coolant and charged battery (maintenance free).

KHM 595 PS

Setting range, A	10-595
Max output at 60% duty cycle, A	550
Max output at 100% duty cycle, A	500
Open circuit voltage, V	60
AC Power generation:	
Three Phase kVA/V/A	30/400
Single Phase kVA/V/A	15/230
Engine type	Perkins 1103C - 33G3
Sound level, dB(A)/LWA	71/96
Power, kW/rpm	30.4 (40.7)/1500
Weight, kg	980

Ordering information

KHM 595 PS (50 Hz)	0794 003 883
2 wheel site tow	0794 018 880
PHG1, remote control 20m	0794 008 881
Earthing kit	0794 017 880
V/A-meter kit	0794 000 160
Connector kit for Origo™ Feed, M13	0740 741 881

MMA welding cables

ESAB has a wide range of MMA welding cables. 150A and 200A can be ordered as a complete cable-kit or as separate welding- or return cables.

From 250A and up, the cables are to be ordered separately.

Ordering information

Complete cable kits with small OKC:

MMA Cable-kit 150A, Crocodile, 16 mm ² , 3+3 m, OKC 25 (Confort 200+MK 150)	0349 501 078
MMA Cable-kit 150A, Twist, 16 mm ² , 3+3 m, OKC 25 (Handy 200+MK 150)	0349 501 079
MMA Cable-kit 200A, Twist, 25 mm ² , 5+5 m, OKC 25 (Handy 200+MP 200)	0700 006 881

Separate welding cables with electrode holder and small OKC:

MMA welding cable 200A, Twist, 25 mm ² , 5 m, OKC 25 (Handy 200)	0700 006 882
MMA welding cable 250A, Twist, 35 mm ² , 5 m, OKC 25 (Handy 300)	0700 006 886

Separate welding cables with electrode holder and large OKC:

MMA welding cable 150A, Twist, 16 mm ² , 3 m, OKC 50 (Handy 200)	0700 006 898
MMA welding cable 200A, Twist, 25 mm ² , 3 m, OKC 50 (Handy 200)	0700 006 900
MMA welding cable 300A, Twist, 35 mm ² , 3 m, OKC 50 (Handy 300)	0700 006 902
MMA welding cable 300A, Twist, 35 mm ² , 5 m, OKC 50 (Handy 300)	0700 006 888
MMA welding cable 400A, Twist, 50 mm ² , 5 m, OKC 50 (Handy 400)	0700 006 890
MMA welding cable 500A, Twist, 50 mm ² , 5 m, OKC 50 (ESAB 500)	0700 006 892
MMA welding cable 500A, Twist, 70 mm ² , 5 m, OKC 95 (ESAB 500)	0700 006 894
MMA welding cable 600A, Crocodile, 95 mm ² , 5 m, OKC 95 (Optimus 600)	0700 006 896

Separate return cables with clamp and small OKC:

Return cable 200A, 25 mm ² , 5 m, OKC 25 (MP200)	0700 006 883
Return cable 250A, 35 mm ² , 5 m, OKC 25 (MP200)	0700 006 887

Separate return cables with clamp and large OKC:

Return cable 150A, 16 mm ² , 3 m, OKC 50 (MK150)	0700 006 899
Return cable 200A, 25 mm ² , 3 m, OKC 50 (MP200)	0700 006 901
Return cable 300A, 35 mm ² , 3 m, OKC 50 (MP300)	0700 006 903
Return cable 300A, 35 mm ² , 5 m, OKC 50 (MP300)	0700 006 889
Return cable 500A, 50 mm ² , 5 m, OKC 50 (EG 600)	0700 006 893
Return cable 500A, 70 mm ² , 5 m, OKC 95 (EG 600)	0700 006 895
Return cable 600A, 95 mm ² , 5 m, OKC 95 (EG 600)	0700 006 897



TIG equipment

DC Inverters



Caddy® Tig 1500i/2200i, TA33

Compact and portable inverter for TIG welding, with HF or LiftArc™ start, and MMA.

- Durable and impact resistant design with OKC 50 cable connectors.
- Easy to operate. All basic settings for quality TIG welding available.
- Digital display for settings.
- Plate thickness setting for TIG. Set the plate thickness and the machine will control the welding parameters.
- Adjustable slope down and gas post-flow.
- ArcPlus™ II regulator for better MMA welding characteristics. Higher weld quality with less after treatment.
- Caddy® Tig 1500i welds most electrodes from Ø 1.6 - 3.2 mm and some 4 mm electrodes.
- Caddy® Tig 2200i welds most electrodes from Ø 1.6 - 4 mm.
- Can operate with extra long mains cables, over 100 m.
- IP 23 – designed for outdoor use making it safe on all work sites

Delivery includes

3 m mains cable with plug, 2 m gas hose and two hose clamps.

	Caddy® Tig 1500i, TA33	Caddy® Tig 2200i, TA33
Mains supply, V/Hz	230/1 50/60	230/1 50/60
Fuse, slow, A	16	16
Mains cable, Ø mm ²	3x2.5	3x2.5
Max output at 25% duty cycle, A	150/16 (TIG)	220/18.8 (TIG)
Max output at 60% duty cycle, A	120/14.8 (TIG)	150/16.0 (TIG)
Max output at 100% duty cycle, A	110/14.4 (TIG)	110/14.4 (TIG)
Current range TIG DC, A	3 - 150	3/220
Current range MMA DC, A	4 - 150	4/170
Open circuit voltage (VRD off/on), V	72/NA	46-60/<35
Power factor at max current	0.99	0.99
Weight, kg	9.2	9.4

Ordering information

Caddy® Tig 1500i, TA33 package incl. 3 m MMA cable kit compl. and Tig torch TXH™ 150, 4 m	0460 450 880
Caddy® Tig 2200i, TA33 package incl. 3 m MMA cable kit compl. and Tig torch TXH™ 200, 4m	0460 450 881
Caddy® Tig 2200iw, TA33 package incl. water cooler, 3 m MMA cable kit compl. and Tig torch TXH™ 250w, 4m	0460 450 884
Caddy® Tig 1500i, TA33 incl. 3 m return cable with clamp	0460 450 890
Caddy® Tig 2200i, TA33 incl. 3 m return cable with clamp	0460 450 891
Caddy® Tig 2200iw, TA33 incl. 3 m return cable with clamp	0460 450 894
Shoulder strap	0460 265 003
Caddy® bag on wheels	Y000 512 880



Caddy® Tig 1500i/2200i, TA34

Compact and portable inverter for advanced TIG welding, with HF or Lift-Arc™ start, and MMA.

- Durable and impact resistant design with OKC 50 cable connectors.
- Easy to operate. Graphical parameter setting for advanced TIG welding.
- Digital display for settings.
- Remote control possibility.
- Pulsed TIG giving increased control of heat input and weld pool.
- Two memories for storing of settings.
- Micro Pulse minimising heat affected zone especially on thin material.
- Adjustable slope up/down and gas post-flow.
- ArcPlus™ II regulator for better MMA welding characteristics. Higher weld quality with less after treatment.
- Caddy® Tig 1500i welds most electrodes from Ø 1.6 - 3.2 mm and some 4 mm electrodes.
- Caddy® Tig 2200i welds most electrodes from Ø 1.6 - 4 mm.
- Can operate with extra long mains cables, over 100 m.
- IP 23 – designed for outdoor use making it safe on all work sites

Delivery includes

3 m mains cable with plug, 2 m gas hose and two hose clamps.

	Caddy® Tig 1500i, TA34	Caddy® Tig 2200i, TA34
Mains supply, V/Hz	230/1 50/60	230/1 50/60
Fuse, slow, A	16	16
Mains cable, Ø mm ²	3x2.5	3x2.5
Max output at 25% duty cycle, A	150/16 (TIG)	220/18.8 (TIG)
Max output at 60% duty cycle, A	120/14.8 (TIG)	150/16.0 (TIG)
Max output at 100% duty cycle, A	110/14.4 (TIG)	110/14.4 (TIG)
Current range TIG DC, A	3 - 150	3 - 220
Current range MMA DC, A	4 - 150	4 - 170
Open circuit voltage (VRD off/on), V	46-60/<35	46-60/<35
Power factor at max current	0.98	0.99
Weight, kg	9.2	9.4

Ordering information

Caddy® Tig 1500i, TA34 package incl. 3 m MMA cable kit compl. and Tig torch TXH™ 150, 4m	0460 450 882
Caddy® Tig 2200i, TA34 package incl. 3 m MMA cable kit compl. and Tig torch TXH™ 200, 4m	0460 450 883
Caddy® Tig 2200iw, TA34 package incl. water cooler, 3 m MMA cable kit compl. and Tig torch TXH™ 250w, 4m	0460 450 885
Caddy® Tig 1500i, TA34 incl. 3 m return cable + clamp	0460 450 892
Caddy® Tig 2200i, TA34 incl. 3 m return cable + clamp	0460 450 893
Caddy® Tig 2200iw, TA34 incl. 3 m return cable + clamp	0460 450 895
Shoulder strap	0460 265 003
Foot pedal T1 Foot CAN incl. 5 m cable	0460 315 880
Caddy® bag on wheels	Y000 512 880

TIG equipment

DC Inverters



Origo™ Tig 3001i, TA23

For both industrial use and repair and maintenance applications. The sturdy design makes the Origo™ Tig 3001i suitable for welding anywhere. It is easy to use and reliable in operation. The Origo™ TA23 is a control panel with the basic settings for TIG welding. The panel gives a good overview of all settings, to make operating as quick and efficient as possible. With the Origo™ Tig 3001i you can weld stainless and mild steels, from plate thickness of 1.0 mm.

Delivery includes

5 m mains cable with plug, 2 m gas hose with 2 hose clamps, return cable 4.5 m with clamp.

Origo™ Tig 3001i, TA23	
Mains supply, V/Hz	400/3~50/60
Fuse, slow, A	16
Mains cable, Ø mm ²	4x4
Max output at 35% duty cycle, A	300/22.0
Max output at 60% duty cycle, A	240/19.6
Max output at 100% duty cycle, A	200/18.0
Slope up, s	0-10
Slope down, s	0-10
Gas pre-flow, s	0-5
Gas post-flow, s	0-25
Open circuit voltage (VRD off/on), V	60/<35
Current range TIG DC, A	4-300
Current range MMA DC, A	16-300
Weight, kg	33.5

Ordering information

Origo™ Tig 3001i, TA23	0459 745 883
Origo™ Tig 3001iw, TA23 (incl. CoolMidi 1000)	0459 745 884
Protection frame	0460 459 880



Origo™ Tig 3001i, TA24

For advanced industrial use and for repair and maintenance. This TIG machine will give a safe start and stable arc. All types of stainless and mild steel and most other materials, from plate thickness of 0.5 mm can be welded with high quality. Productivity with the right quality is important. The control panel Origo™ TA24 has all the necessary functions for advanced TIG DC, Pulse TIG and MMA welding. All parameters presented in an easy to understand way.

Delivery includes

5 m mains cable with plug, 2 m gas hose with 2 hose clamps, return cable 4.5 m with clamp.

Origo™ Tig 3001i, TA24	
Mains supply, V/Hz	400/3~50/60
Fuse, slow, A	16
Mains cable, Ø mm ²	4x4
Max output at 35% duty cycle, A	300/22.0
Max output at 60% duty cycle, A	240/19.6
Max output at 100% duty cycle, A	200/18.0
Slope up, s	0-10
Slope down, s	0-10
Gas pre-flow, s	0-5
Gas post-flow, s	0-25
Open circuit voltage (VRD off/on), V	60/<35
Current range TIG DC, A	4-300
Current range MMA DC, A	16-300
Weight, kg	33.5

Ordering information

Origo™ Tig 3001i, TA24	0459 745 885
Origo™ Tig 3001iw, TA24 (incl. CoolMidi 1000)	0459 745 886
Protection frame	0460 459 880

TIG equipment

DC Inverters



Aristo[®] Tig 4000i

Outstanding welding characteristics – high efficiency and high-quality welding.

Efficient Man Machine Communication by the user-friendly control panels Aristo[®] TA4 and Aristo[®] TA6.

TA6 enables a memory of 10 welding parameters and the possibility to weld with the pulse technique, which is especially suitable for thin materials.

- Enclosure class IP 23
- Adjustable pre-gas, slope-up, post-gas and slope-down to control starts and avoid cracks and oxidation at the end
- Dust filter to handle tough and dirty environments and avoid grinding-dust and metal particles inside the chassis

Delivery includes

5 m mains cable incl. plug and return cable with clamp

Aristo[®] Tig 4000i

Mains supply, V/Hz	3x400/50-60
Fuse, slow, A	25
Mains cable, Ø mm ²	4x4
Max output at 35% duty cycle, A	400/26 V
Max output at 60% duty cycle, A	320/23 V
Max output at 100% duty cycle, A	250/20 V
Slope up, s	0-5
Slope down, s	0-10
Gas pre-flow, s	0-5
Gas post-flow, s	0-200
Open circuit voltage (VRD off/on), V	58/<35
Setting range, A	4-400
Weight, kg	61.5

Ordering information

Aristo [®] Tig 4000i TA4	0458 630 880
Aristo [®] Tig 4000i TA6	0458 630 884
Aristo [®] Tig 4000i TA4 with water-cooling unit	0458 630 881
Aristo [®] Tig 4000i TA6 with water-cooling unit	0458 630 885

TIG equipment

AC/DC Inverters



Caddy® Tig 2200i AC/DC

Compact and portable inverter for AC/DC TIG welding, with HF or LiftArc™ start, and MMA.

- Durable and impact resistant design with OKC 50 cable connectors.
- Easy to operate.
- Digital display for settings.
- Plate thickness setting for TIG (TA33 AC/DC). Set the plate thickness and the machine will control the welding parameters.
- Adjustable slope down and gas post-flow (TA33 AC/DC).
- DC pulsed TIG (TA34 AC/DC) giving increased control of heat input and weld pool.
- Two memories (TA34 AC/DC) for storing of settings.
- Micro Pulse (TA34 AC/DC) minimising heat affected zone especially on thin material.
- Adjustable slope up/down and gas post-flow (TA34 AC/DC).
- Remote control possibility.
- ArcPlus II regulator for better MMA welding characteristics. Higher weld quality with less after treatment.
- All types of material, including aluminium, and thickness up to 5 mm
- Can operate with extra long mains cables, over 100 m, thanks to the built-in PFC circuit.
- IP 23 – designed for outdoor use making it safe on all work sites.

Delivery includes

3 m of mains cable, 2 m of gas hose with two hose clamps. Return cable 3 m incl. earth clamp.

	Caddy® Tig 2200i AC/DC, TA34 AC/DC	Caddy® Tig 2200i AC/DC, TA33 AC/DC
Mains supply, V/Hz	230/1 50/60	230/1 50/60
Fuse, slow, A	16	16
Mains cable, Ø mm ²	3 x 2.5	3 x 2.5
Max output at 20% duty cycle, TIG, A/V	220/18.8	220/18.8
Max output at 60% duty cycle, TIG, A/V	150/16.0	150/16.0
Max output at 100% duty cycle, TIG, A/V	140/15.6	140/15.6
Slope up, s	0-10	0-9.9
Slope down, s	0-10	0-10
Gas pre-flow, s	0-5	0-5
Gas post-flow, s	0-25	0-25
Open circuit voltage VRD (off/on), V	46-60/<35	46-60/<35
Setting range TIG AC/DC	3-220	3-220
Setting range MMA	4-160	4-160
Weight, kg	15	15

Ordering information

Caddy® Tig 2200i AC/DC, TA33 AC/DC, TXH™ 200 4m, MMA Kit	0460 150 882
Caddy® Tig 2200i AC/DC, TA34 AC/DC, TXH™ 200 4m, MMA Kit	0460 150 883
Caddy® Tig 2200i AC/DC, TA34 AC/DC, TXH™ 250w 4m, water cooler CoolMini, MMA kit, two-wheel trolley	0460 150 884
Caddy® Tig 2200i AC/DC, TA34 AC/DC	0460 150 880
Caddy® Tig 2200i AC/DC, TA33 AC/DC	0460 150 881
Cooling unit, CoolMini	0460 144 880



Origo™ Tig 3000i AC/DC, TA24 AC/DC

In both DC and AC mode this TIG welding machine will give an excellent start and stable arc. All types of material and thicknesses can be welded with the highest quality.

- Designed for quality TIG-welding in all types of material.
- QWave™ – enables AC welding with high arc stability and low noise.
- AC frequency and balance control optimizes weld pool.
- DC pulsed TIG welding gives easy control of heat input.
- ESAB 2-program function. Possibility to pre-program and change program during welding.
- Easy to use. All parameters presented in an easily comprehensible way.
- MMA welding: Hot start, arc force and polarity switch.

Delivery includes

5 m of mains cable, 2 m of gas hose with 2 hose clamps, return cable 4.5 m incl. earth clamp.

	Origo™ Tig 3000i AC/DC
Mains supply, V/Hz	400/50-60
Fuse, slow, A	20
Mains cable, Ø mm ²	4x4
Max output at 35% duty cycle, TIG, A	300
Max output at 60% duty cycle, TIG, A	240
Max output at 100% duty cycle, TIG, A	200
Slope up, s	0-10
Slope down, s	0-10
Gas pre-flow, s	0-5
Gas post-flow, s	0-25
Open circuit voltage, V	54-64
Setting range TIG AC/DC, A/V	4-300
Setting range, A	16-300
Weight, kg	42

Ordering information

Origo™ Tig 3000i AC/DC, TA24 AC/DC	0459 735 880
Cooling unit, CoolMidi 1800	0459 840 880

TIG equipment

AC/DC Inverters



Origo™ Tig 4300iw AC/DC, TA24 AC/DC

- Designed for quality TIG-welding in all types of material.
- QWave™ – enables AC welding with high arc stability and low noise.
- AC Frequency and Balance control – Optimises weld pool
- DC Pulsed TIG welding – easy control of heat input and the weld pool.
- ESAB LogicPump – ELP, automatic start of the cooling unit by connection of a liquid-cooled torch
- Energy save mode – fan and pump on demand
- ESAB 2-program function – possibility to pre-program and change program during actual welding.
- Easy to use – All welding parameters presented in an easy to understand panel.
- MMA welding in AC and DC mode – Hot start, Arc force, and polarity switch (DC).

Delivery includes

5 m mains cable incl plug, 2 m gas hose incl. 2 hose clamps and return cable 5 m incl earth clamp.

Origo™ Tig 4300iw AC/DC

Mains supply, V/Hz	400/3
Fuse, slow, A	25
Mains cable, Ø mm ²	4x4
Max output at 40% duty cycle, TIG, A/V	430/27.2
Max output at 60% duty cycle, TIG, A/V	400/26
Max output at 100% duty cycle, TIG, A/V	315/22.6
Slope up, s	0-10
Slope down, s	0-10
Gas pre-flow, s	0-10
Gas post-flow, s	0-25
Open circuit voltage (VRD off/on), V	60/<35
Setting range TIG AC/DC	4-430
Setting range MMA	16-430
Weight, kg	95

Ordering information

Origo™ Tig 4300iw AC/DC, TA 24 AC/DC 0460 100 880



Tigaid 315 AC/DC

The Tigaid 315 AC/DC is a useful tool for converting MMA machines, transformers and rectifiers for TIG applications. Tigaid controls the supply of current, HF ignition and gas flow. When stepless and electronically-controlled MMA power sources are used, it is possible to obtain current setting and slope functions.

Tigaid 315 AC/DC

Mains supply, V/Hz	115/230/240, 50/60
Fuse, slow, A	10
Mains cable, Ø mm ²	3x1.5
Max output at 35% duty cycle, A	315
Slope up, s	0.1-10
Slope down, s	0.1-10
Gas pre-flow, s	0.1-5.0
Gas post-flow, s	1.0-60
Weight, kg	15

Ordering information

Tigaid 315 AC/DC, OKC-connection	0369 136 882
Connection kit for self-cooled torch and power source with remote control socket type Burndy	0467 348 880
Connection kit for water-cooled torch and power source with Burndy socket	0467 348 881
Connection kit for air-cooled torch and power source without remote socket	0467 348 882

TIG equipment

Torches and components



TXH™ 120, 120V, 120F

The major characteristic for the TXH™ torch program is its quality. The torches and torch outfits are designed to provide the utmost in convenience, versatility and ergonomics.

They are air-cooled, with or without gas valve and with or without a flexible neck. It all depends on the job.

- 120 A torch with start switch – small size and perfect access in confined areas.
- Built-in gas valve for manual control of the shielding gas by hand (120V).
- Flexible heads offer unlimited versatility for reaching hard-to-get-at applications (120F)

Ordering information

TXH™ 120, OKC 4 m	0460 010 842
TXH™ 120, OKC 8 m	0460 010 882
TXH™ 120V, OKC25 4 m	0460 010 841
TXH™ 120V, OKC25 8 m	0460 010 881
TXH™ 120F, OKC 4 m	0460 010 844
TXH™ 120F, OKC 8 m	0460 010 884
TXH™ 120, OKC25 4 m*	0460 010 940
TXH™ 120, OKC25 8 m*	0460 010 980
TXH™ 120, OKC25C 4 m**	0460 010 840
TXH™ 120, OKC25C 8 m**	0460 010 880

*Only Origo™ Tig 150i

** Only Caddy® Tig 150i



TXH™ 150, 150V, 150F

The major characteristic for the TXH™ torch program is its quality. The torches and torch outfits are designed to provide the utmost in convenience, versatility and ergonomics.

They are air-cooled, with or without gas valve and with or without a flexible neck. It all depends on the job.

- Effective cooling – small size and perfect access in confined areas.
- Rugged design – trouble-free operation with low maintenance.
- Built-in gas valve for manual control of the shielding gas by hand (150V).
- Flexible heads offer unlimited versatility for reaching hard-to-get-at applications (150F).
- Ergonomic handle.

Ordering information

TXH™ 150, OKC 4 m	0460 011 842
TXH™ 150, OKC 8 m	0460 011 882
TXH™ 150V, OKC 4 m	0460 011 843
TXH™ 150V, OKC 8 m	0460 011 883
TXH™ 150F, OKC 4 m	0460 011 845
TXH™ 150F, OKC 8 m	0460 011 885
TXH™ 150, OKC25 4 m*	0460 011 940
TXH™ 150, OKC25 8 m*	0460 011 980
TXH™ 150, OKC25C 4 m**	0460 011 840
TXH™ 150, OKC25C 8 m**	0460 011 880

*Only Origo™ Tig 150i

** Only Caddy® Tig 150i

TIG equipment

Torches and components



TXH™ 200, 200V, 200F

The major characteristic for the TXH™ torch program is its quality. The torches and torch outfits are designed to provide the utmost in convenience, versatility and ergonomics. They are air-cooled with or without gas valve and with or without a flexible neck. It all depends on the job.

- Effective cooling – small size and perfect access in confined areas.
- Rugged design – trouble-free operation with low maintenance.
- Built-in gas valve for manual control of the shielding gas (200V).
- Flexible heads offer unlimited versatility for reaching hard-to-get-at applications (200F).
- Ergonomic handle.

Ordering information

TXH™ 200, OKC 4 m	0460 012 840
TXH™ 200, OKC 8 m	0460 012 880
TXH™ 200V, OKC 4 m	0460 012 841
TXH™ 200V, OKC 8 m	0460 012 881
TXH™ 200F, OKC 4 m	0460 012 842
TXH™ 200F, OKC 8 m	0460 012 882



TXH™ 250w, 250wF, 400w, 400w HD

The major characteristic for the TXH™ torch program is its quality. The torches and torch outfits are designed to provide the utmost in convenience, versatility and ergonomic. These are water-cooled, with or without a flexible neck. It all depends on the job.

- Effective cooling – small size and perfect access in confined areas.
- Rugged design – trouble-free operation with low maintenance.
- Flexible heads offer unlimited versatility for reaching hard-to-get-at applications (250wF).
- Ergonomic handle.
- The HD is a model in the TXH™ range to match Origo™ Tig 4300iw AC/DC

Ordering information

TXH™ 250w, OKC 4 m	0460 013 840
TXH™ 250w, OKC 8 m	0460 013 880
TXH™ 250wF, OKC 4 m	0460 013 841
TXH™ 250wF, OKC 8 m	0460 013 881
TXH™ 400w, OKC 4 m	0460 014 840
TXH™ 400w, OKC 8 m	0460 014 880
TXH™ 400w HD, OKC 4 m	0460 014 841
TXH™ 400w HD, OKC 8 m	0460 014 881

TIG equipment

Torches and components



TXH™ remote torches

With the TXH™ range with remote it is possible to adjust the welding current during welding and between welds with two buttons in the handle marked with + and -.

A complete solution consists of a TXH™ torch with the +/- buttons and a remote adapter, RA T1, to connect the torch to all ESAB CAN-bus controlled machines. The adapter must only be bought once and all the different torches fit to the same adapter.

Ordering information

TXH™ 120r, OKC 4 m	0462 010 842
TXH™ 120r, OKC 8 m	0462 010 882
TXH™ 120Fr, OKC 4 m	0462 010 844
TXH™ 120Fr, OKC 8 m	0462 010 884
TXH™ 150r, OKC 4 m	0462 011 842
TXH™ 150r, OKC 8 m	0462 011 882
TXH™ 150Fr, OKC 4 m	0462 011 845
TXH™ 150Fr, OKC 8 m	0462 011 885
TXH™ 200r, OKC 4 m	0462 012 840
TXH™ 200r, OKC 8 m	0462 012 880
TXH™ 200Fr, OKC 4 m	0462 012 842
TXH™ 200Fr, OKC 8 m	0462 012 882
TXH™ 250wr, OKC 4 m	0462 013 840
TXH™ 250wr, OKC 8 m	0462 013 880
TXH™ 250wFr, OKC 4 m	0462 013 841
TXH™ 250wFr, OKC 8 m	0462 013 881
TXH™ 400wr, OKC 4 m	0462 014 840
TXH™ 400wr, OKC 8 m	0462 014 880
TXH™ 400wr HD, OKC 4 m	0462 014 841
TXH™ 400wr HD, OKC 8 m	0462 014 881
Remote adapter kit RA T1 incl. holder and 0.25 m cable with 12-pole plug	0459 491 912
Remote adapter kit RAT1 incl. holder and 0.25 m cable with 10-pole plug.	0459 491 913



TIG equipment

Torches and components

TXH™ 120 (r, F, Fr, V) – TXH™ 400w (r, HD, wr HD)

Wear parts

Tungsten electrodes Eco

Ordering no. 150 mm	Ordering no. 175 mm	Tungsten electrodes Eco	Diameter	Colour	Code	Current
0151 574 208	0151 574 008	Wolfram, pure	Ø 1.0	Green	WP	AC
0151 574 209	0151 574 009	Wolfram, pure	Ø 1.6	Green	WP	AC
0151 574 245	–	Wolfram, pure	Ø 2.0	Green	WP	AC
0151 574 210	0151 574 010	Wolfram, pure	Ø 2.4	Green	WP	AC
0151 574 211	0151 574 011	Wolfram, pure	Ø 3.2	Green	WP	AC
0151 574 212	0151 574 012	Wolfram, pure	Ø 4.0	Green	WP	AC
0151 574 201	0151 574 001	Thorium 2%	Ø 1.0	Red	WT20	DC
0151 574 202	0151 574 002	Thorium 2%	Ø 1.6	Red	WT20	DC
0151 574 244	–	Thorium 2%	Ø 2.0	Red	WT20	DC
0151 574 203	0151 574 003	Thorium 2%	Ø 2.4	Red	WT20	DC
0151 574 204	0151 574 004	Thorium 2%	Ø 3.2	Red	WT20	DC
0151 574 205	0151 574 005	Thorium 2%	Ø 4.0	Red	WT20	DC
0151 574 236	0151 574 036	Cerium 2%	Ø 1.0	Grey	WC20	AC/DC
0151 574 237	0151 574 037	Cerium 2%	Ø 1.6	Grey	WC20	AC/DC
0151 574 242	–	Cerium 2%	Ø 2.0	Grey	WC20	AC/DC
0151 574 238	0151 574 038	Cerium 2%	Ø 2.4	Grey	WC20	AC/DC
0151 574 239	0151 574 039	Cerium 2%	Ø 3.2	Grey	WC20	AC/DC
0151 574 240	0151 574 040	Cerium 2%	Ø 4.0	Grey	WC20	AC/DC
0151 574 230	0151 574 050	Lantan 1.5%	Ø 1.0	Gold	WL15	AC/DC
0151 574 231	0151 574 051	Lantan 1.5%	Ø 1.6	Gold	WL15	AC/DC
0151 574 232	–	Lantan 1.5%	Ø 2.0	Gold	WL15	AC/DC
0151 574 233	0151 574 052	Lantan 1.5%	Ø 2.4	Gold	WL15	AC/DC
0151 574 234	0151 574 053	Lantan 1.5%	Ø 3.2	Gold	WL15	AC/DC
0151 574 235	0151 574 054	Lantan 1.5%	Ø 4.0	Gold	WL15	AC/DC
–	0151 574 055	Lantan 1.5%	Ø 4.8	Gold	WL15	AC/DC

TIG equipment

Torches and components

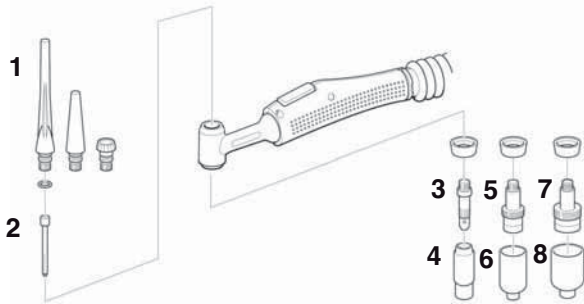

TXH™ 120 (r, F, Fr, V) – TXH™ 400w (r, HD, wr HD)

Nozzles, collets, collet bodies and gas lenses for TXH™ torches

Pos	Size	Denomination	TXH™ 120/250w 120F/250F*	TXH™ 150/200 150F/200F*	TXH™ 400w/400w HD
1.	Long	Back cap	0365 310 051	0157 123 029	0157 123 029
	Med.		0365 310 050	0588 000 591	0588 000 591
	Short		0365 310 049*	0157 123 028*	0157 123 028
2.	Ø 1.0	Collet standard and for gas lens	0365 310 028	0157 123 010	0157 123 010
	Ø 1.6		0365 310 029	0157 123 011	0157 123 011
	Ø 2.0-2.4		0365 310 030	0157 123 012	0157 123 077
	Ø 3.2		0365 310 091	0157 123 013	0157 123 078
	Ø 4.0		–	0157 123 014	0157 123 079
	Ø 4.8		–	–	0157 123 074
3.	Ø 1.0	Collet body standard	0365 310 037	0157 123 015	0157 123 081
	Ø 1.6		0365 310 038	0157 123 016	0157 123 081
	Ø 2.0-2.4		0365 310 039	0157 123 017	0157 123 081
	Ø 3.2		0365 310 090	0157 123 018	0157 123 082
	Ø 4.0-4.8		–	0157 123 019	0157 123 082
		Heat shield	0366 960 017	0366 960 016	0366 960 018
4.	Ø 6.4	Gas nozzles standard	0365 310 044	0157 123 052	0157 123 057
	Ø 8.0		0365 310 045	0157 123 053	0157 123 058
	Ø 9.8		0365 310 046	0157 123 054	0157 123 059
	Ø 11.2		0365 310 047	0157 123 055	0157 123 060
	Ø 12.7		0365 310 048	0157 123 056	0157 123 061
	Ø 15.9		0588 000 440	0588 000 442	–
	Ø 19.0		–	0588 000 441	–
5.	Ø 1.0	Collet body with gas lens	0157 121 016	0157 123 021	0157 123 091
	Ø 1.6		0157 121 017	0157 123 022	0157 123 092
	Ø 2.0-2.4		0157 121 018	0157 123 023	0157 123 093
	Ø 3.2		0157 121 041	0157 123 024	0157 123 094
	Ø 4.0		–	0157 123 025	0157 123 095
	Ø 4.8		–	–	0157 123 075
		Heat shield	0366 960 017	0366 960 020	0366 960 018
6.	Ø 6.4	Gas nozzle for gas lens	0157 121 032	0157 123 057	0157 123 057
	Ø 8.0		0157 121 033	0157 123 058	0157 123 058
	Ø 9.8		0157 121 034	0157 123 059	0157 123 059
	Ø 11.2		0157 121 039	0157 123 060	0157 123 060
	Ø 12.7		0157 121 040	0157 123 061	0157 123 061
	Ø 17.5		–	0588 000 439	0588 000 439
7.	Ø 1.0	Collet body with extra large gas lens		0157 123 083	–
	Ø 1.6			0157 123 084	–
	Ø 2.0-2.4			0157 123 085	–
	Ø 3.2			0157 123 086	0157 123 103
	Ø 4.0-4.8		0157 123 087	0157 123 105	
	Heat shield		0366 960 021	0366 960 018	
8.	Ø 9.8	Extra large gas nozzle for extra large gas lens	–	0157 123 088	0157 123 088
	Ø 12.7		–	0157 123 089	0157 123 089
	Ø 15.9		–	0588 000 438	0588 000 438
	Ø 19.0		–	0157 123 098	0157 123 098
	Ø 24.0		–	0588 000 437	0588 000 437

Bold = standard delivery

MIG/MAG equipment

Compacts, Step controlled



Origo™ Mig C141/C151

The Origo™ Mig C141 and C151 are the ideal welding machines for the less complex welding application, but where a high quality result is of the uppermost importance. Both are step regulated welding power sources with a built-in wire feeder. These low weight units are perfect, practical solutions for farmers, repair shops and light production applications.

Delivery includes

Welding torch MXL™ 150V, 2.5 m (contact tip 0.8), assembled feed roller 0.6-0.8, 3m mains cable with plug, 3m return cable with clamp, gas hose 1.5m, shelf for gas cylinder (for Origo™ Mig C141 - as option) and attachment chain for gas cylinder.

	Origo™ Mig C141	Origo™ Mig C151
Mains supply, V/Hz	230 1ph 50/60	230 1ph 50/60
Max output at 20% duty cycle, A	100	150
Max output at 60% duty cycle, A	54	87
Max output at 100% duty cycle, A	42	67
Wire feed, m/min	2.0-14	2.0-14
Open circuit voltage, V	18.7 - 25.1	17.3 - 24.3
Weight, kg	25	37.5

Ordering information

Origo™ Mig C141 (230V 1 ph 50/60 Hz)	0349 311 170
Origo™ Mig C151 (230V 1 ph 50/60 Hz)	0349 311 180
Wheel kit (for Origo™ Mig C141)	0349 309 073



Origo™ Mag C171/C201/C251

The Origo™ Mag C171, C201 and C251 are step controlled welding power sources for MIG/MAG welding. A built-in wire feeder and the low weight of the units make them perfect, practical solutions for use on farms, in repair shops and for light production applications.

Delivery includes

Origo™ Mag C171/C201; MXL™ 200, 3 m (contact tip 0.8), assembled feed roller 0.6-0.8.

Origo™ Mag C251; MXL™ 270, 3 m (contact tip 1.0), assembled feed roller 0.8-1.0.

All units; 3m mains cable with plug, 3m return cable with clamp, gas hose 1.5m, shelf for gas cylinder and attachment chain for gas cylinder.

	Origo™ Mag C171	Origo™ Mag C201	Origo™ Mag C251
Mains supply, V/Hz	230 1ph 50/60	230 1ph 50/60	230 1ph 50/60
Max output at 20% duty cycle, A	170	200	250
Max output at 60% duty cycle, A	98	115	140
Max output at 100% duty cycle, A	76	90	110
Wire feed, m/min	1-17	1-17	1.9-19
Interval/spot welding	0.2-2.5	0.2-2.5	0.2-2.5
Open circuit voltage, V	22.5 - 44.5	19.6 - 44.9	19.0 - 41.5
Weight, kg	59	68	94

Ordering information

Origo™ Mag C171 (230V 1 ph 50/60 Hz)	0349 311 280
Origo™ Mag C201 (230V 1 ph 50/60 Hz)	0349 311 290
Origo™ Mag C251 (230V 1 ph 50/60 Hz)	0349 311 420
Digital instrument	0349 302 598
Transformer for CO ₂ heater (42V 50/60 Hz)	0349 302 250

MIG/MAG equipment

Compacts, Step controlled



Origo™ Mig C170 3ph/C200 3ph/C250 3ph

The Origo™ Mig C170 3ph/C200 3ph/C250 3ph are three-phase step regulated welding power sources for MIG/MAG welding. A built-in wire feeder and the low weight of the units make them perfect, practical solutions for farmers, repair shops and light production users.

Delivery includes

Origo™ Mig C170/C200 3ph: MXL™ 200, 3 m (contact tip 0.8), assembled feed roller 0.6-0.8. Origo™ Mig C250 3ph: MXL™ 270, 3 m (contact tip 1.0), assembled feed roller 0.8-1.0. All units: 3 m mains cable with plug, 3m return cable with clamp, gas hose 1.5 m, shelf for gas cylinder and attachment chain for gas cylinder.

	Origo™ Mig C170 3ph	Origo™ Mig C200 3ph	Origo™ Mig C250 3ph
Mains supply, V/Hz	400-415 3ph 50/60	400-415 3ph 50/60	230/400-415 3ph 50/60
Max output at 35% duty cycle, A	170	200	250
Max output at 60% duty cycle, A	130	150	190
Max output at 100% duty cycle, A	100	120	150
Wire feed, m/min	1-17	1-17	1-17
Interval/spot welding	0.2-2.5	0.2-2.5	0.2-2.5
Open circuit voltage, V	15.5-30.6	16-31.8	15-37
Weight, kg	63.5	72.5	82

Ordering information

Origo™ Mig C170 3ph (400-415V 3ph 50/60 Hz)	0349 308 670
Origo™ Mig C200 3ph (400-415V 3ph 50/60 Hz)	0349 308 290
Origo™ Mig C250 3ph (400-415V 3ph 50/60 Hz)	0349 307 840
Origo™ Mig C250 3ph (230/400-415V 3ph 50/60 Hz)	0349 309 090
Digital instrument	0349 302 598
Transformer for CO ₂ heater (42V 50/60 Hz)	0349 302 250
Polarity change KIT (Origo™ Mig C170)	0349 309 310



Origo™ Mig C280 PRO/C340 PRO

The Origo™ Mig C280 PRO/C340 PRO are step-regulated compact power sources for MIG/MAG welding. They are designed for light- to medium-duty applications.

The Origo™ Mig C280 PRO is a 10 voltage-step unit. The operator can adjust wire-feed speed, burnback time and spot-welding time. The Origo™ Mig C340 PRO is a 40 voltage-step unit. The units come with a fitted V/A meter kit. The operator can adjust wire-feed speed and select 2- or 4-stroke control and creep start. Strong, galvanised metal casing and built-in wire feeder make both units practical, mobile solutions.

Delivery includes

PSF™ 250, 3 m (for Origo™ Mig C280 PRO), PSF™ 250, 4.5 m (for Origo™ Mig C280 PRO 4WD), PSF™ 305, 3 m (for Origo™ Mig C340 PRO), PSF™ 305, 4.5 m (for Origo™ Mig C340 PRO 4WD), 5 m mains cable, wheels, 3.5 m return cable (5 m for 4WD) with clamp and shelf for gas cylinder.

	Origo™ Mig C280 PRO	Origo™ Mig C340 PRO
Mains supply, V/Hz	400-415 50/60*	400-415 50/60*
Max output at 30% duty cycle, A	280	340
Max output at 60% duty cycle, A	190	250
Max output at 100% duty cycle, A	150	195
Wire feed, m/min	1.9-19	1.9-20
Wire Ø, unall. solid	0.6-1.0	0.6-1.2
Wire Ø, SS	0.6-1.0	0.6-1.2
Wire Ø, Al	1.0-1.2	1.0-1.2
Wire Ø, CW	1.0-1.2	1.0-1.2
Interval/spot welding	0.2-2.5	-
Open circuit voltage, V	15-38	16-40
Weight, kg	91	114

Ordering information

Origo™ Mig C280 PRO (400-415 V, 50 Hz)	0349 312 510
Origo™ Mig C280 PRO*	0349 312 540
Origo™ Mig C280 PRO 4WD (400-415 V, 50 Hz)	0349 312 520
Origo™ Mig C280 PRO 4WD*	0349 312 530
Origo™ Mig C340 PRO (400-415 V, 50 Hz)	0349 312 550
Origo™ Mig C340 PRO*	0349 312 560
Origo™ Mig C340 PRO 4WD*	0349 312 570
Air filter	0349 302 599
Transformer for CO ₂ heater	0349 302 250
Cable holder	0349 303 362
Push-pull KIT for Mig C340	0349 308 980

*230/400-415/500 V, 50 Hz; 230/440-460 V, 60 Hz

MIG/MAG equipment

Compacts, Step controlled/Inverters



Origo™ Mig C420 PRO/C420w PRO

The Origo™ Mig C420 PRO is a step-regulated compact power source for MIG/MAG welding. It is designed for heavy-duty applications.

The Origo™ Mig C420 PRO is a 35 voltage-step unit and three inductance outlets help to select the right arc dynamic setup.

The units come with a fitted V/A meter kit.. The operator can adjust wire-feed speed, burnback time and select 2- or 4-stroke control. An optional air filter that keeps metal dust and dirt out of the power source complete the offer.

Delivery includes

Welding torch PSF™ 405/PSF™ 410w 4.5 m, 5 m mains cable with plug, 5 m return cable with clamp, gas hose 1.5 m, shelf for gas cylinder and attachment chain for gas cylinder.

Origo™ Mig C420 PRO/ C420w PRO

Mains supply, V/Hz	400-415 50/60
Max output at 50% duty cycle, A	420
Max output at 60% duty cycle, A	400
Max output at 100% duty cycle, A	315
Wire feed, m/min	1.9-25
Wire Ø, unall. solid	0.6-1.6
Wire Ø, SS	0.6-1.6
Wire Ø, Al	0.8-1.6
Wire Ø, CW	0.9-1.6
Interval/spot welding	0.9-2.0
Open circuit voltage, V	14-47
Weight, kg	215/230

Ordering information

Origo™ Mig C420w PRO (400-415 V, 50/60 Hz)	0349 312 590
Origo™ Mig C420 PRO (400-415 V, 50/60 Hz)	0349 312 580
Air filter	0349 302 252
Transformer for CO ₂ heater	0349 302 250
Water flow guard	0349 302 251
Cable holder	0349 303 362



Caddy® Mig C160i

Portable MIG/MAG welding unit with built-in wire feeder for Ø200 mm spools.

Caddy® Mig C160i is used for MIG/MAG welding of mild steels for repair, maintenance and assembly work. This easy to use and powerful unit offers excellent welding properties and is easy to take along to the job at hand. Great if you are welding in the workshop or on the move.

With Caddy® Mig C160i you only need to set the plate thickness before starting to weld. Hotter or colder welds can easily be obtained by using the heat adjustment knob.

Delivery includes

3 m torch, 3 m mains cable with plug, 4.5 m gas hose with hose clamp and quick connector, return cable with clamp, simple shoulder strap, fitted wear parts in torch/feeder for Ø0.8 mm wire. 1 kg OK Autrod 12.51, Ø0.8 mm welding wire is also included.

Caddy® Mig C160i

Mains supply, V/Hz	230 +/- 15%/1ph 50/60
Fuse, slow A	16
Mains cable, Ø mm ²	3x1.5
Setting range, A	30-160
Max output at 35% duty cycle, A/V	150/20.5
Max output at 100% duty cycle, A/V	100/19
Wire feed, m/min	2-11
Open circuit voltage, V	60
Power factor at max. current	0.99
Weight, kg	11.4

Ordering information

Caddy® Mig C160i, 1ph 230V	0349 310 850
1/2 pallet with 6 Caddy® Mig C160i	0349 312 272
Trolley with gas shelf	0459 366 887

MIG/MAG equipment

Compacts Inverters



Caddy® Mig C200i

Portable Mig/Mag welding unit with built-in wire feeder for Ø200 mm spools. For tradesmen – repair, maintenance and assembly welding of mild steels, aluminium and stainless steels as well as brazing. This easy to use, intelligent and powerful unit offers excellent welding properties and is easy to take along to the job at hand. Great if you are welding in the workshop or on the move. Equipped with QSet™ – intelligent setting of welding parameters giving a perfect arc for all material and gas combinations. Single-knob control for consistent and optimal weld quality for all plate thicknesses.

Delivery includes

3 m torch, 3 m mains cable with plug. 4.5 m gas hose with hose clamp and quick connector, return cable with clamp, simple shoulder strap, fitted wear parts in torch/feeder (for 0,8 mm wire). 1 kg OK Autrod 12.51, Ø0.8 mm welding wire is also included.

Caddy® Mig C200i

Mains supply, V/Hz	230 +/- 15%/1ph 50/60
Fuse, slow A	16
Mains cable, Ø mm2	3x1.5
Setting range, A	30-200
Max output at 25% duty cycle, A/V	180/23
Max output at 100% duty cycle, A/V	100/19
Wire feed, m/min	2-12
Open circuit voltage, V	60
Power factor at max. current	0.99
Weight, kg	11.5

Ordering information

Caddy® Mig C200i, 1ph 230V	0349 312 030
Trolley with gas shelf	0459 366 887



Origo™ Mig C3000i, MA23A

Origo™ Mig C3000i, MA23A is a compact machine with integrated wire feeder for professional use in general applications up to 300 A. QSet™ is an integrated function in the MA23A panel which provides a unique way of setting welding parameters for short arc. QSet™ is smart - give it a few seconds of test welding and watch how the short arc stabilizes automatically. The optimised setting is maintained regardless of the wire feed speed setting.

Delivery includes

Welding torch PSF™ 305, 4.5 m. 5 m mains cable with plug and 4.5 m return cable with clamp.

Origo™ Mig C3000i

Mains supply, V/Hz	3~400, 50/60
Max output at 35% duty cycle, A	300/29V
Max output at 60% duty cycle, A	240/24V
Max output at 100% duty cycle, A	200/24V
Wire feed, m/min	0.8-25.0
Wire Ø, unall. solid	0.6-1.2
Wire Ø, SS	0.6-1.2
Wire Ø, Al	1.0-1.2
Wire Ø, CW	0.8-1.2
Open circuit voltage (VRD off/on), V	60/<35
Weight, kg	38

Ordering information

Origo™ Mig C3000i, MA23A	0459 750 881
Water cooler CoolMidi 1800	0459 840 880

MIG/MAG equipment

Compacts Inverters, Semi-automats step controlled



Aristo[®] Mig C3000i, U6

This is a compact machine with built in wire feeder for professional use in advanced applications up to 300 A. Aristo[®] Mig C3000i, U6 is ideal for efficient production and pre-fabrication of high alloy materials up to 5 mm thickness in applications with very high demands on welding performance. The Aristo[®] U6 control panel has synergic MIG/MAG, synergic Pulsed MIG, QSet[™] as well as MMA functionality. 10 memories can be stored and setting limits can be programmed to secure the weld quality.

Delivery includes

5 m mains cable with plug and 4.5 m return cable with clamp.

Aristo[®] Mig C3000i

Mains supply, V/Hz	3~400, 50/60
Max output at 35% duty cycle, A	300/29V
Max output at 60% duty cycle, A	240/26V
Max output at 100% duty cycle, A	200/24V
Wire feed, m/min	0.8-25.0
Wire Ø, unall. solid	0.6-1.2
Wire Ø, SS	0.6-1.2
Wire Ø, Al	1.0-1.2
Wire Ø, CW	0.8-1.2
Open circuit voltage (VDR off/on), V	60/<35
Weight, kg	38

Ordering information

Aristo [®] Mig C3000i, U6	0459 750 882
Water cooler CoolMidi 1800	0459 840 880



Origo[™] Mig L405

The Origo[™] Mig L405 welding package is ideal for welding applications within vehicle repair workshops, general steel fabrication, household and furniture manufacturers.

A complete package consists of the Origo[™] Mig L405 power source, Origo[™] Feed L302 or L304 wire feed units, a connection set and a PSF[™] welding torch.

- 40 voltage steps optimum settings for each application.
- Two inductance outlets – easy to optimise settings for different applications.
- V/A meter kit available as option.
- IP 23 – fit for safe outdoor applications.
- Easy-to-use panel for quick set up.

Delivery includes

5 m mains cable, wheels, return cable with clamp, gas bottle platform and a guide pin for the wire feeder.

Origo[™] Mig L405

Mains supply, V/Hz	230/400-415/500, 3~ 50; 230/400-460, 3~ 60
Fuse, slow, A	20
Mains cable, Ø mm ²	4x2.5
Max output at 25% duty cycle, A/V	-
Max output at 50% duty cycle, A/V	400/34
Max output at 60% duty cycle, A/V	365/32
Max output at 100% duty cycle, A/V	280/28
Open circuit voltage, V	17-45
Weight, kg	142

Ordering information

Origo [™] Mig L405 (400-415V 50Hz)	0349 306 517
Origo [™] Mig L405 (230/400-415 500V 50Hz; 230/440-460 60Hz)	0349 306 594
Origo [™] Mig L405w (400-415V 50Hz)	0349 306 563
Digital meter kit	0349 302 451

MIG/MAG equipment

Semi-automats step controlled



Origo™ Mig 320

The Origo™ Mig 320 is a step-regulated power source for MIG/MAG welding. It is designed for medium-duty applications. It is a 40 voltage-step unit and it has two inductance outlets. The units come with a fitted V/A meter kit. Strong, galvanised metal casing makes this unit the perfect solution for harsh environments. Wide voltage and current range optimise settings for various applications.

The large wheels, sturdy lifting eyelets and an under carriage designed for transportation with fork-lifts make the unit easy to move. The Origo™ Mig 320 operates with the separate wire feeders Origo™ FeedAirmatic, Origo™ Feed 302 M11, 304 M12 and 484 M12 and Origo™ YardFeed 200 (without V/A meter).

Delivery includes

5 m mains cable, wheels, 5 m return cable with clamp, shelf for gas cylinder and a guide pin for the wire feeder.

Origo™ Mig 320	
Mains supply, V/Hz	400-415, 3~50/60
Fuse, slow, A	20-16
Mains cable, Ø mm ²	4x2.5
Max output at 30% duty cycle, A	320
Max output at 60% duty cycle, A	250
Max output at 100% duty cycle, A	195
Setting range, A	40-320
Open circuit voltage, V	16-40
Weight, kg	111

Ordering information

Origo™ Mig 320 (400-415 V, 50/60 Hz)	0349 303 562
Origo™ Mig 320*	0349 312 600
Air filter	0349 302 599
Cable holder	0349 303 362
Transformer for CO ₂ heater	0349 302 250
Stabilizer	0349 303 475

*230/400-415/500 V, 50 Hz; 230/440-460 V, 60 Hz

Multivoltage version available on request



Origo™ Mig 410/510

The Origo™ Mig 410 and 510 are step-regulated power sources for MIG/MAG welding designed for heavy-duty applications. They are 40 voltage-step units available as water- or air-cooled versions. The Origo™ Mig 410 has two inductance outlets, while the Origo™ Mig 510 has three inductance outlets. The units come with a fitted V/A meter kit. Origo™ Mig 410/510 operate with the separate wire feeders Origo™ FeedAirmatic, Origo™ Feed 302 M11, 304 M12 and 484 M12 and Origo™ YardFeed 200 (without V/A meter).

Delivery includes

5 m mains cable, wheels, 5 m cable with clamp, shelf for gas cylinder and a guide pin for wire feeder.

	Origo™ Mig 410	Origo™ Mig 510
Mains supply, V/Hz	400-415	400-415
Fuse, slow, A	20	35
Mains cable, Ø mm ²	4x2.5	4x6
Max output at 50% duty cycle, A	400	-
Max output at 60% duty cycle, A	365	500
Max output at 100% duty cycle, A	280	390
Open circuit voltage, V	17-45	17-50
Weight, kg	144	214

Ordering information

Origo™ Mig 410*	0349 312 610
Origo™ Mig 410w*	0349 312 620
Origo™ Mig 410 (400-415 V, 50/60 Hz)	0349 303 563
Origo™ Mig 410w (400-415 V, 50/60 Hz)	0349 303 564
Origo™ Mig 510*	0349 312 630
Origo™ Mig 510w*	0349 312 640
Origo™ Mig 510 (400-415 V, 50/60 Hz)	0349 303 565
Origo™ Mig 510w (400-415 V, 50/60 Hz)	0349 303 566
Air filter	0349 302 423
Cable holder	0349 303 362
Water flow guard	0349 302 251
Transformer for CO ₂ heater	0349 302 250
Stabilizer	0349 303 474
Reinforcer kit for counterbalance	0349 309 748

*230/400-415/500 V, 50 Hz; 230/440-460 V, 60 Hz

Multivoltage version available on request.

MIG/MAG equipment

Semi-automats, Choppers



Origo™ Mig 402c/502c/652c

Origo™ Mig 402c/502c/652c are sturdy and robust switching converter (chopper) power sources intended for heavy duty MIG/MAG welding, MMA welding and air-arc gouging. Well proven technology together with ESAB developed software provides high reliability and outstanding welding performance.

Delivery includes

5m mains cable incl plug for 400V, wheels, return cable with clamps, gas bottle platform and a guide pin for the wire feeder.

	Origo™ Mig 402c	Origo™ Mig 502c	Origo™ Mig 652c
Mains supply, V/Hz	400-415, 3~ 50/60	400-415, 3~ 50/60	400-415, 3~ 50/60
Fuse, slow, A	25	35	50
Mains cable, Ø mm ²	4x4	4x6	4x10
Max output at 60% duty cycle, A	400 / 34	500 / 39	650 / 44
Max output at 100% duty cycle, A	310 / 30	400 / 34	500 / 39
Open circuit voltage, V	53-70	53-70	53-70
Weight, kg	158	194	228

Ordering information

Origo™ Mig 402c (400-415V 50/60Hz)	0349 310 750
Origo™ Mig 402c (230/400-415/500V 50Hz ; 230/440-460 60Hz)	0349 311 220
Origo™ Mig 402cw (400-415V 50/60Hz)	0349 308 500
Origo™ Mig 402cw (230/400-415/500V 50Hz ; 230/440-460 60Hz)	0349 311 230
Origo™ Mig 502c, A13 (400-415V 50/60Hz)	0349 310 770
Origo™ Mig 502c, A13 (230/400-415/500V 50Hz ; 230/440-460 60Hz)	0349 311 240
Origo™ Mig 502cw, A13 (400-415V 50/60 Hz)	0349 310 760
Origo™ Mig 502cw, A13 (230/400-415/500V 50Hz ; 230/440-460 60Hz)	0349 311 250
Origo™ Mig 652c, A13 (400-415V 50/60Hz)	0349 311 060
Origo™ Mig 652c, A13 (230/400-415/500V 50Hz ; 230/440-460 60Hz)	0349 311 260
Origo™ Mig 652cw, A13 (400-415V 50/60 Hz)	0349 310 800
Origo™ Mig 652cw, A13 (230/400-415/500V 50Hz ; 230/440-460 60Hz)	0349 311 270
Accessories:	
Air filter	0349 302 252
Digital V/A-meter for A13 MMC panel (Mig 502c/652c)	0455 173 882
Transformer for CO ₂ -heater	0349 302 250
Water flow guard	0349 302 251
Cable holder kit	0349 303 362
Feed selector	0349 311 680
LiftArc™ start kit	0349 311 530
A13 MMC Panel with V/A-meter (Mig 402c)	0349 310 396
Mounting kit "Fan on demand"	0349 311 690



Origo™ Mig 4002c/5002c/6502c

Mig 4002c, 5002c, and 6502c are sturdy and robust switching converter (chopper) power sources intended for heavy duty applications.

MIG/MAG and MMA are the main processes – process selection being related to the choice of control panel, Origo™ MA23, Origo™ MA24 or Aristo® U6.

Well proven technology together with ESAB developed software provides high reliability and outstanding welding performance.

Delivery includes

5m mains cable, wheels, return cable with clamps, gas bottle platform and a guide pin for the wire feeder.

	Origo™ Mig 4002c	Origo™ Mig 5002c	Origo™ Mig 6502c
Mains supply, V/Hz	400-415, 3~50-60	400-415, 3~50/60	400-415, 3~50-60
Fuse, slow, A	25	35	50
Mains cable, Ø mm ²	4x4	4x6	4x10
Max output at 60% duty cycle, A	400 / 34	500 / 39	650 / 44
Max output at 100% duty cycle, A	310 / 30	400 / 34	500 / 39
Open circuit voltage, V	62 MIG/ MAG, 68 MMA	62 MIG/ MAG, 68 MMA	62 MIG/ MAG, 68 MMA
Weight, kg	149	185	222

Ordering information

Origo™ Mig 4002c (400-415V 50/60Hz)	0349 311 300
Origo™ Mig 4002c (230/400-415/500V 50Hz ; 230/440-460 60Hz)	0349 311 310
Origo™ Mig 4002cw (400-415V 50/60Hz)	0349 309 780
Origo™ Mig 4002cw (230/400-415/500V 50Hz ; 230/440-460 60Hz)	0349 311 320
Origo™ Mig 5002c (400-415V 50/60Hz)	0349 311 330
Origo™ Mig 5002c (230/400-415/500V 50Hz ; 230/440-460 60Hz)	0349 311 340
Origo™ Mig 5002cw (400-415V 50/60 Hz)	0349 311 350
Origo™ Mig 5002cw (230/400-415/500V 50Hz ; 230/440-460 60Hz)	0349 311 360
Origo™ Mig 6502c (400-415V 50/60Hz)	0349 311 370
Origo™ Mig 6502c (230/400-415/500V 50Hz ; 230/440-460 60Hz)	0349 311 380
Origo™ Mig 6502cw (400-415V 50/60 Hz)	0349 311 390
Origo™ Mig 6502cw (230/400-415/500V 50Hz ; 230/440-460 60Hz)	0349 311 400
Accessories:	
Air filter	0349 302 252
Transformer for CO ₂ -heater	0349 302 250
Water flow guard	0349 302 251
Cable holder kit	0349 303 362

MIG/MAG equipment

Semi-automats, Inverters



Origo™ Mig 3001i, A24 – Mig 3001i/3001iw

Origo™ Mig 3001i is an ideal partner when it comes to efficient production or prefabrication of high alloyed materials with a very high demand on the welding performance.

The power source is compact and sturdy with a chassis made of galvanised steel. This is a robust material that withstands rough treatment.

The power source is optimised to operate together with the wire feeders Origo™ Feed 3004/4804, Aristo® Feed 3004/4804 or YardFeed 2000. Connection cables up to 50 m provides a working radius of up to 54.5 meter to suit all your individual welding needs.

Delivery includes

5 m mains cable incl. plug and 4.5 m return cable incl. earth clamp.

Origo™ Mig 3001i, A24 – Mig 3001i/3001iw

Mains supply, V/Hz	400, 3~ 50/60
Fuse, slow, A	16
Mains cable, Ø mm ²	4x4
Max output at 35% duty cycle, A	300/29.0
Max output at 60% duty cycle, A	240/26.0
Max output at 100% duty cycle, A	200/24.0
Current range MIG, A	16-300
Current range MMA DC, A	16-300
Current range TIG DC, A	4-300
Open circuit voltage (VRD off/on), V	60/<35
Weight, kg	33
Weight incl. cooling unit and coolant, kg	53

Ordering information

Mig 3001i	0459 740 882
Mig 3001iw	0459 740 883
Origo™ Mig 3001i, A24	0459 740 884
Trolley 2-wheel	0460 564 880
Feeder platform for Trolley 2-wheel	0460 815 880
Trolley 4-wheel	0460 565 880
Stabilizer kit Trolley 4w, for Counterbalance device (only one Counterbalance device per trolley)	0460 946 880
Mounting bracket kit (for rack mounting etc)	0460 911 880
Water Flow guard complete for Mig 3001iw	0456 855 881
Protection frame	0460 459 880



Origo™ Mig 4001i, A24 – Mig 4001i/4001iw

Origo™ Mig 4001i is an ideal partner when it comes to efficient production or prefabrication of high alloyed materials with a very high demand on the welding performance.

The power source is compact and sturdy with a chassis made of galvanised steel. This is a robust material that withstands rough treatment.

The power source is optimised to operate together with the wire feeders Origo™ Feed 3004/4804, Aristo® Feed 3004/4804 or YardFeed 2000. Connection cables up to 50 m provides a working radius of up to 54.5 meter to suit all your individual welding needs.

Delivery includes

5 m mains cable incl plug and 5 m return cable incl earth clamp.

Origo™ Mig 4001i, A24 – Mig 4001i/4001iw

Mains supply, V/Hz	400, 3~ 50/60
Fuse, slow, A	20
Mains cable, Ø mm ²	4x4
Max output at 35% duty cycle, A	400/34
Max output at 60% duty cycle, A	320/30
Max output at 100% duty cycle, A	250/26.5
Current range MIG, A	20-400
Current range MMA DC, A	16-400
Current range TIG DC, A	4-400
Open circuit voltage (VRD off/on), V	60/<35
Weight, kg	43.5
Weight incl. cooling unit and coolant, kg	63.5

Ordering information

Mig 4001i	0460 455 882
Mig 4001iw	0460 455 883
Origo™ Mig 4001i, A24	0460 455 884
Trolley 2-wheel	0460 564 880
Feeder platform Trolley 2-wheel	0460 815 880
Protection frame	0460 459 880
Trolley 4-wheel	0460 565 880
Water Flow guard complete for Mig 4001iw	0456 855 881
Water Flow guard complete for Mig 4001iw	0456 855 881
Stabilizer kit Trolley 4w, for Counterbalance device (only one Counterbalance device per trolley)	0460 946 880

MIG/MAG equipment

Semi-automats, Inverters



MIG/MAG equipment

Semi-automats, Inverters



Aristo[®] Mig 5000i

- Multi-process power source combining MIG/MAG, pulse MIG, MMA and carbon arc gouging
- Reliable, smooth starts and ends, supported by efficient hot-start and crater-fill functions.
- Efficient man-machine communication by the user-friendly control panels MA4, U6 or Aristo[®] U8₂
- Wide range of pre-programmed synergic lines for any material or gas combination.
- Memory for 10 (U6) or 255 (Aristo[®] U8₂) welding parameters.
- ESAB LogicPump, ELP, secures the automatic start of the water pump by connecting a water-cooled welding torch.
- Dust filter to handle tough, dirty environments and avoid grinding-dust and metal particles inside the chassis.
- Operates with the separate wire feeders Aristo[®] Feed 3004/4804 MA4, U6 and Aristo[®] U8₂, Aristo[®] RoboFeed 3004w and Aristo[®] YardFeed 2000.

Delivery includes

5 metre mains cable incl. plug and 5 m return cable with clamp

Aristo[®] Mig 5000i

Mains supply, V/Hz	3x400/50-60
Fuse, slow, A	35
Mains cable, Ø mm ²	4x6
Max output at 35% duty cycle, A	-
Max output at 60% duty cycle, A	500/40 (MMA)
Max output at 100% duty cycle, A	400/36 (MMA)
Current range MIG, A	16-500
Current range MMA DC, A	16-500
Current range TIG DC, A	-
Open circuit voltage (VRD off/on), V	59/<35
Weight, kg	68

Ordering information

Aristo [®] Mig 5000i (3x400 V, 50/60 Hz)	0459 230 880
Aristo [®] Mig 5000iw (3x400 V, 50/60 Hz)	0459 230 881



Aristo[®] Mig U4000i/U5000i

- Efficient man-machine communication by the user-friendly control panel U6 or Aristo[®] U8₂
- Wide range of pre-programmed synergic lines. Aristo[®] U8₂ provides the facility to define and store customised synergic lines for any material and gas combination.
- Memory for 10 (U6) or 255 (Aristo[®] U8₂) welding parameters
- ESAB LogicPump, ELP, secures the automatic start of the water pump by connecting a water-cooled welding torch to the wire feeder or a water-cooled TIG torch
- TrueArcVoltage System™, measures the correct arc voltage value, independent of the length of the connection cable, return cable or welding torch
- Dust filter to handle tough and dirty environments and avoid grinding-dust and metal particles inside the chassis
- The Aristo[®] Mig U4000i/U5000i operate with the separate wire feeders Aristo[®] Feed 3004/4804 U6 and Aristo[®] U8₂.

Delivery includes

5 m mains cable incl. plug and 5 m return cable with clamp

Aristo[®] Mig U4000i Aristo[®] Mig U5000i

Mains supply, V/Hz	3x400/50-60	3x400/50-60
Fuse, slow, A	25	35
Mains cable, Ø mm ²	4x4	4x6
Max output at 35% duty cycle, A	400/36 (MMA)	-
Max output at 60% duty cycle, A	320/33 (MMA)	500/40 (MMA)
Max output at 100% duty cycle, A	250/30 (MMA)	400/36 (MMA)
Current range MIG, A	20-400	16-500
Current range MMA DC, A	16-400	16-500
Current range TIG DC, A	4-400	4-500
Open circuit voltage (VRD off/on), V	58/<35	59/<35
Weight, kg	63.5	71

Ordering information

Aristo [®] Mig U4000i (3x400 V, 50/60 Hz)	0458 625 884
Aristo [®] Mig U4000iw (3x400 V, 50/60 Hz)	0458 625 885
Aristo [®] Mig U5000i (3x400 V, 50/60 Hz)	0459 230 882
Aristo [®] Mig U5000iw (3x400 V, 50/60 Hz)	0459 230 883

MIG/MAG equipment

Wire feeders



Origo™ FeedAirmatic, M10

- Suitable for Mig 320/410/510/402c/502c and 652c.
 - The push-pull system ensures smooth, problem-free wire feed which is especially important when welding soft aluminium or other thin wires.
 - Permits welding hose packages of up to 16 m
 - Extended working radius with connection cables of up to 35 m
 - Digital V/A meters (option)
 - TrueArcVoltage System, measures the correct arc voltage value independent of the length of the connection cable, return cable or welding hose package
 - Extra versatility can be achieved by attaching a counterbalance device, wheel kit and hanging bracket.
 - Enclosed wire spool keeps the wire clean.
- Allen key, hose clamp and five inlet nozzles for PKB included.

Origo™ FeedAirmatic

Mains supply, V/Hz	42, 50/60
Wire feed, m/min	max 15
Max spool dimension/weight, Ø mm/kg	300 (440)/18 (30)
Wire Ø, unall. solid	0.6-1.6
Wire Ø, SS	0.6-1.6
Wire Ø, Al	0.8-1.6
Wire Ø, CW	0.8-1.6
Weight, kg	15

Ordering information

Origo™ FeedAirmatic, M10, enclosed – 23 pole	0459 116 680
Accessories Origo™ Mig 402c/502c/652c:	
Adapter 19 pole – 23 pole	0349 311 511
Counter balance device compl. 300 mm bobbin	0458 705 880
Counter balance device compl. 440 mm bobbin	0458 705 882
Wheel kit	0458 707 880
Spool cover, steel	0459 431 880
Strain relief for welding torch	0457 341 881
Strain relief for interconnection cables	0459 234 880
Lifting eye	0458 706 880
Quick connector MARATHON PAC™	F102 440 880
Adapter for 5 kg spool	0455 410 001
Adapter for spool diameter 440 mm	0459 233 880
Remote control MIG 2 (only voltage adjustment)	0349 501 028
Remote control M1 (only voltage adjustment)	0459 491 895
Remote interconnection cable M1, 5m	0459 553 880
Digital V/A meter for Origo™ Mig 402c/502c/652c	0455 173 882



Origo™ Feed L302/L304

- Suitable for Origo™ Mig L305/L405.
- 2/4 stroke, simplifies welding.
- Adjustable burnback timer gives correct stick-out.
- Creep start, (L304) gradual wire feed for ultimate starts.
- Spot welding (L304) for easy operation with presetting of the timer and equal lengths for the spots.
- Gas Purge and Inching (L304) no wire or gas wastage when initially setting up the equipment for welding or changing the wire spool.

Origo™ Feed L302 Origo™ Feed L304

Mains supply, V/Hz	42, 50/60	42, 50/60
Wire feed, m/min	1.5-22.0	1.5-22.0
Max spool dimension/weight, Ø mm/kg	300/18	300/18
Wire Ø, unall. solid	0.6-1.2	0.6-1.6
Wire Ø, SS	0.6-1.2	0.6-1.2
Wire Ø, Al	1.0-1.2	1.0-1.6
Wire Ø, CW	0.8-1.2	0.8-1.6
Weight, kg	12.6	13.2

Ordering information

Origo™ Feed L302, open	0459 495 782
Origo™ Feed L304, open	0459 495 882
Origo™ Feed L304w, open	0459 495 892
Bobbin cover, plastic	0458 674 880
Wheel kit	0458 707 880
Strain relief for welding torch	0457 341 881
Strain relief for connection cables	0459 234 880
Quick connector MARATHON PAC™	F102 440 880
Lifting eye	0458 706 880
Adapter for 5 kg spool	0455 410 001
Counter balance device	0458 705 880

MIG/MAG equipment

Wire feeders



Origo™ Feed 302/304/484, M11/M12

- Suitable for Origo™ Mig 320, 410 and 510.
- 2/4 stroke, simplifies welding.
- Adjustable burn-back time produces correct stick-out.
- Creep start, gradual wire feed for ultimate starts.
- Quick connectors – shortest possible set-up times.
- ESAB LogicPump, ELP, automatically starts the water pump when a water-cooled welding torch is connected.
- TrueArcVoltage System™.

	Origo™ Feed 302	Origo™ Feed 304	Origo™ Feed 484
Mains supply, V/Hz	42, 50/60	42, 50/60	42, 50/60
Wire feed, m/min	1.9-20.0	1.9-25.0	1.9-25.0
Max spool dimension/weight, Ø mm/kg	300/18	300/18	300/18
Wire Ø, unall. solid	0.6-1.2	0.6-1.6	0.6-2.4
Wire Ø, SS	0.6-1.2	0.6-1.6	0.6-2.4
Wire Ø, Al	1.0-1.2	1.0-1.6	1.0-2.4
Wire Ø, CW	0.8-1.2	0.8-1.6	0.8-2.4
Weight, kg	14.3	15	19

Ordering information

Origo™ Feed 302, M11, enclosed	0459 116 781
Origo™ Feed 302w, M11, enclosed	0459 116 791
Origo™ Feed 304, M12, enclosed	0459 116 882
Origo™ Feed 304w, M12, enclosed	0459 116 892
Origo™ Feed 484, M12, enclosed	0459 116 982
Origo™ Feed 484w, M12, enclosed	0459 116 992



Origo™ Feed 304/484, M13-19 pole

- Suitable for Mig 402c/502c and 652c.
- 2/4 stroke and creep start, simplifies start/stop and the gradual feed of the wire helps to optimise the starts.
- Crater filling, eliminates cracks and gives high quality welds.
- Adjustable burn-back time to correct stick-out and reduce wear of contact tips.
- Digital V/A meters.
- Quick connectors- shortest possible set-up times.
- ESAB LogicPump, ELP, secures automatic start of water pump by connection of a water cooled welding torch.
- TrueArcVoltage™ system, measures the correct arc voltage value independent of the length of the interconnection cable, return cable or welding torch.

	Origo™ Feed 304	Origo™ Feed 484
Mains supply, V/Hz	42, 50/60	42, 50/60
Wire feed, m/min	1.9-25.0	1.9/25.0
Max spool dimension/weight, Ø mm/kg	300/18	300/18
Wire Ø, unall. solid	0.6-1.6	0.6-2.4
Wire Ø, SS	0.6-1.6	0.6-2.4
Wire Ø, Al	1.0-1.6	1.0-2.4
Wire Ø, CW	0.8-1.6	0.8-2.4
Weight, kg	15	19

Ordering information

Origo™ Feed 304, M13, enclosed, 19 pole	0459 116 863
Origo™ Feed 304w, M13, enclosed, 19 pole	0459 116 873
Origo™ Feed 304, M13 incl. V/A meters, enclosed, 19 pole	0459 116 864
Origo™ Feed 304w, M13 incl. V/A meters, enclosed, 19 pole	0459 116 874
Origo™ Feed 484, M13, enclosed, 19 pole	0459 116 963
Origo™ Feed 484w, M13, enclosed, 19 pole	0459 116 973
Origo™ Feed 484, M13 incl. V/A meters, enclosed, 19 pole	0459 116 964
Origo™ Feed 484w, M13 incl. V/A meters, enclosed, 19 pole	0459 116 974

MIG/MAG equipment

Wire feeders



Origo™ Feed 3004/4804, MA23/MA24

The sturdy design of the ESAB Origo™ Feed 3004 and 4804, with their galvanised metal casing, makes these units ideal for use in tough environments. Suitable for Mig 3001i/4001i/5000i/4002c/5002c/6502c. Electronically controlled feeding gives an accurate and stable arc and the 4-wheel feeder mechanism with grooves in both the feed roll and pressure roll gives a stable feed with low wear on the wire, all of which helps to avoid operational disturbances.

	Origo™ Feed 3004	Origo™ Feed 4804
Mains supply, V/Hz	42, 50/60	42, 50/60
Wire feed, m/min	0.8-25.0	0.8-25.0
Max spool dimension/weight, Ø mm/kg	300/18	300/18
Wire Ø, unall. solid	0.6-1.6	0.6-2.4
Wire Ø, SS	0.6-1.6	0.6-2.4
Wire Ø, Al	1.0-1.6	1.0-2.4
Wire Ø, CW	0.8-1.6	0.8-2.4
Weight, kg	15	19

Ordering information

Origo™ Feed 3004, MA23 Encl 10 pole	0460 526 887
Origo™ Feed 3004w, MA23 Encl 10 pole	0460 526 897
Origo™ Feed 4804, MA23 Encl 10 pole	0460 526 987
Origo™ Feed 4804w, MA23 Encl 10 pole	0460 526 997
Origo™ Feed 3004, MA24 Encl 10 pole	0460 526 889
Origo™ Feed 3004w, MA24 Encl 10 pole	0460 526 899
Origo™ Feed 4804, MA24 Encl 10 pole	0460 526 989
Origo™ Feed 4804w, MA24 Encl 10 pole	0460 526 999
Accessories Origo™ Feed:	
Wheel kit	0458 707 880
Strain relief for welding torch	0457 341 881
Strain relief for interconnection cables	0459 234 880
Lifting eye	0458 706 880
Quick connector MarathonPac™	F102 440 880
Adapter for 5 kg spool	0455 410 001
Counter balance device	0458 705 880
Spool cover	0458 674 880
Spool cover, steel	0459 431 880
Adapter for spool diameter 440 mm	0459 233 880

MIG/MAG equipment

Wire feeders



Aristo® Feed 3004/4804, U6/U8₂

- Suitable for Mig 3001i/4001i/U4000i/5000i/U5000i/4002c/5002c and 6502c.
- 2/4 stroke, simplifies handling of the welding torch.
- Creep start, gas pre-flow and hot start provide a soft, more direct start with less spatter.
- Crater filling, adjustable burn-back time and post gas provides a smooth finish, extend the service life of the contact tip and guarantee no cracks at the end.
- Pre-programmed synergic lines, to ensure optimal settings.
- Possibility to create synergic lines (Aristo® U8₂).
- Memory for 10 (U6) or 255 (U8₂) parameter sets
- Quick connectors – shortest possible set-up times.
- ESAB LogicPump ELP, secures the automatic start of the water pump by connecting a water-cooled welding torch.
- TrueArcVoltage System™, measures the correct arc voltage value, independent of the length of the connection cable, return cable or welding torch.

	Aristo® Feed 3004	Aristo® Feed 4804
--	-------------------	-------------------

Mains supply, V/Hz	42/50-60	42/50-60
Wire feed, m/min	0.8-25.0	0.8-25.0
Max spool dimension/weight, Ø mm/kg	300/18	300/18
Wire Ø, unall. solid	0.6-1.6	0.6-2.4
Wire Ø, SS	0.6-1.6	0.6-2.4
Wire Ø, Al	1.0-1.6	1.0-2.4
Wire Ø, CW	0.8-1.6	0.8-2.4
Weight, kg	15	19

Ordering information

Aristo® Feed 3004, U6, encl 10p	0460 526 886
Aristo® Feed 3004w, U6, encl 10p	0460 526 896
Aristo® Feed 4804, U6, encl 10p	0460 526 986
Aristo® Feed 4804w, U6, encl 10p	0460 526 996
Aristo® Feed 3004, U8 ₂ encl 10p	0460 526 881
Aristo® Feed 3004w, U8 ₂ encl 10p	0460 526 891
Aristo® Feed 4804, U8 ₂ encl 10p	0460 526 981
Aristo® Feed 4804w, U8 ₂ encl 10p	0460 526 991
Aristo® U8 ₂ complete incl. holder	0460 820 880
Aristo® U8 ₂ Plus complete incl. holder	0460 820 881
Control cable extension 7.5 m	0460 877 891



Aristo® RoboFeed 3004w

Suitable for Mig 3001i/4001i/U4000i/5000i/U5000i/4002c/5002c and 6502c. Aristo® RoboFeed 3004w is a complete feeding unit that includes a drive control system and the operational functions gas purge and wire inching forward and reverse. The unit is equipped with mounting bolts with rubber absorbers to protect components in the event of high acceleration and deceleration power from the robot.

Aristo®
RoboFeed
3004w

Mains supply, V/Hz	42, 50/60
Wire feed, m/min	0.8-30.0
Wire Ø, unall. solid	0.6-1.6
Wire Ø, SS	0.6,-1.6
Wire Ø, Al	1.0-1.6
Wire Ø, CW	0.8-1.6
Weight, kg	7.3

Ordering information

Aristo® RoboFeed 3004w 12p ELP	0461 000 891
Connect. set 7.5 m w95/CAN-Robo	0461 528 991
Connect. set 10 m w95/CAN-Robo	0461 528 993
Assembly bracket universal	0461 038 880
Quick connector MARATHON PAC™	F102 440 880
Wire Conduit 1.8M MPac	F102 437 881
Wire Conduit 3.0M MPac	F102 437 882
Wire Conduit 4.5M MPac	F102 437 883
Wire Conduit 8.0M MPac	F102 437 884
Wire Conduit 12.0M MPac	F102 437 885
Wire Conduit 0.6M MPac	F102 437 886
Wire Conduit 6.0M MPac	F102 437 887
Wire Conduit 5.3M MPac	F102 437 888
Wire Conduit 3.8M MPac	F102 437 889
Wire Conduit 6.5M MPac	F102 437 890

MIG/MAG equipment

Wire feeders



MobileFeed 200AVS / 300AVS

Built for harsh environments such as construction sites, pipe lines, shipyards, offshore, general fabrication, mobile welding rigs and more.

- Arc voltage feeder for use with DC, (CC or CV) power supplies
- Totally enclosed, super impact-resistant case
- Metal reinforced, flame retardant, molded composite plastic case
- 4 roll drive unit with tach feedback for superior wire feeding
- Permanent magnet drive motor with PWM drive, solid state controlled wire acceleration for smooth arc starts and spatter-free operation
- Electronic Dynamic Braking
- Automatic slow wire run-in for improved arc starts.

	MobileFeed 200AVS	MobileFeed 300AVS
Wire feed, m/min	1.8-17.8	1.3-20.3
Max spool dimension/weight, Ø mm/kg	200/5	300/18
Weight, kg	11.8	14.5

Ordering information

MobileFeed 200 AVS	0558 005 796
MobileFeed 300 AVS	0558 005 728



Origo™ YardFeed 200, M13y

- Suitable for Mig 320/410/510 (without V/A meter) /402c/502c and 652c (with V/A meter).
- 2/4 stroke, simplifies handling of the welding torch.
- Safety switch with optional heating element.
- Gas purge and wire inching.
- Manual gas flow valve inside the cabinet.
- Gas flow manometer incl. manual valve (option).
- High strength steel to make the feeder light and robust especially resistant against rough handling.
- Integrated handle in a protective frame simplifies the handling through man-holes and other difficult-to-access areas.
- Equipped with military standard control cable connector.
- Adjustable burn-back timer provides a smooth finish and extends the lifetime of the contact tip.
- Quick connectors- shortest possible set-up times.
- ESAB LogicPump, ELP, secures automatic start of water pump by connection of a water cooled welding torch.
- TrueArcVoltage System™, measures the correct arc voltage value independent of the length of the connection cable, return cable or welding torch.

	Origo™ YardFeed 200
Mains supply, V/Hz	42, 50/60
Wire feed, m/min	1.9-25.0
Max spool dimension/weight, Ø mm/kg	200/5
Wire Ø, unall. solid	0.6-1.2
Wire Ø, SS	0.6-1.2
Wire Ø, Al	1.0-1.2
Wire Ø, CW	0.8-1.4
Weight, kg	11.3

Ordering information

Origo™ YardFeed 200, M13y 19 pole	0459 906 881
Origo™ YardFeed 200w, M13y 19 pole	0459 906 891
Origo™ YardFeed 200, M13y incl. V/A meter	0459 906 882
Origo™ YardFeed 200w, M13y incl. V/A meter	0459 906 892
Strain relief for welding torch	0457 341 881
Gas flow manometer kit	0460 005 880
Heating element kit	0459 041 880
MMC protection	0459 961 880

MIG/MAG equipment

Wire feeders



Aristo[®] YardFeed 2000, U6 Origo[™] YardFeed MA23

- Suitable for Mig 3001i/4001i/U4000i//5000i/U5000i/4002c/5002c and 6502c
- 2/4 stroke, simplifies handling of the welding torch.
- Safety switch with optional heating element
- Gas purge and wire inching
- Manual gas flow valve inside the cabinet
- Gas flow manometer incl. manual valve (option)
- Equipped with military standard control cable connector
- Creep start, gas pre-flow and hot start provide a soft and more direct start with less spatter (U6).
- Crater filling, adjustable burn-back time and post gas provides a smooth finish, extend the lifetime of the contact tip and guarantees no cracks at the end (U6).
- Pre-programmed synergic lines, to ensure optimum settings with a wide choice of materials, wire dimensions and gas combinations (U6).
- Memory for 3 (MA23) or 10 (U6) parameter sets
- ESAB LogicPump, ELP, secures automatic start of water pump by connection of a water cooled welding torch.

Aristo[®] YardFeed 2000

Mains supply, V/Hz	42, 50/60
Wire feed, m/min	0.8-25.0
Max spool dimension/weight, Ø mm/kg	200/5
Wire Ø, unall. solid	0.6-1.2
Wire Ø, SS	0.6-1.2
Wire Ø, Al	1.0-1.2
Wire Ø, CW	0.8-1.4
Weight, kg	11.3

Ordering information

Aristo [®] YardFeed 2000, U6 10p	0459 906 886
Aristo [®] YardFeed 2000w, U6 10p	0459 906 896
Origo [™] YardFeed 2000, MA23 10p	0459 906 887
Origo [™] YardFeed 2000w, MA23 10p	0459 906 897
Strain relief for welding torch	0457 341 881
Gas flow manometer kit	0460 005 880
Heating element kit	0459 941 880
Remote interconnection cable 5 m	0459 960 880
MMC protection	0459 961 880
OKC angel connection for MMA	0365 557 001

MIG/MAG equipment



Aristo® W8₂



Aristo® U8₂

Aristo® U8₂/W8₂

Aristo® U8₂ creates a whole new universe of possibilities; maximum functionality, minimum complexity. Five function buttons, single menu and “Enter” button and three setting wheels cover every option. Large bright easy-view LED display and knurled setting wheels for simple gloves-on, visor-down operation.

Aristo® U8₂ or Aristo® U8₂ Plus, the all-new U8₂ control unit is the key to a fully integrated welding system. Full USB connectivity and a broad choice of advanced add-on modules Aristo® W8₂ (DeviceNet, Profibus, CANopen and Ethernet) for comprehensive Fieldbus and LAN communication.

Optional synergic-line packs for special materials can be offered on request.

Ordering information

Aristo® U8 ₂	0460 820 880
Aristo® U8 ₂ Plus	0460 820 881
Aristo® U8 ₂ Plus I/O	0460 820 882
Aristo® W8 ₂ Integrated	0460 891 880
Aristo® W8 ₂ Fieldbus (Device Net)	0460 891 881
Aristo® W8 ₂ Fieldbus (Profibus)	0460 891 882
Aristo® W8 ₂ Fieldbus (CANopen)	0460 891 883



WeldPoint™

WeldPoint™ is a PC based tool to handle a multitude of administration and monitoring tasks for ESAB welding systems connected to a Local Area Network (LAN) by a TCP/IP address. WeldPoint™ also enables data to be uploaded or downloaded to or from the computer by a USB memory stick as an alternative for applications that do not require the continuous communication possibilities presented by LAN connection.

Views

WeldPoint™ consists of 7 views. Each view is responsible for particular tasks.

Main view is responsible for establishing connection(s) with the welding system (weld data unit's).

Get files from weld data unit downloads the files from the welding system.

View weld data helps the user to view the content of the weld data file.

Compose new weld data is used to combine two weld data's to create a new weld data.

Online quality data viewer helps the user to receive quality data in real-time.

Online weld data editor supports editing of setting data online.

Remote USB-memory access supports up and downloading of files to/from the connected weld data unit.

Ordering information

WeldPoint™	0462 045 880
------------	--------------

MIG/MAG equipment

Assembly possibilities for wire feeders



Counterbalance device/mast

The feeder unit is assembled with a spring unit which lifts the welding torch and hose with adjustable force. The lifting force is independent of the weight of the wire spool. The device can be rotated through 360°.

Ordering information

Counterbalance device for Aristo® Feed and Origo™ Feed 0458 705 880



Turning piece

The feeder unit can be rotated on the power source through 360°.

Ordering information

Turning piece for Aristo® Feed and Origo™ Feed MPac versions 0458 703 880



Wheel kit

Increases the working radius from the power source. The wheel kit has four wheels and can also be placed to pivot on the power source.

Ordering information

Wheel kit 1 Feed L302/L304/302/304/3004/484/4804. Front wheels turnable. 0458 707 880

Wheel kit 2 Feed L302/L304/302/304/3004/484/4804. All wheels turnable. 0458 707 881



Lifting eye

Using this device, the feeder unit can be suspended in a swinging arm.

Ordering information

Lifting eye for Aristo® Feed/Origo™ Feed/Origo™ Feed L302/304 and Aristo®/Origo™ Feed L3004 0458 706 880



Strain relief for welding torch

Recommended in combination with wheel kit.

Ordering information

Strain relief for Aristo® Feed/Origo™ Feed, Aristo® Feed L3004/Origo™ Feed L3004 and Aristo® YardFeed 2000/Origo™ YardFeed 200 0457 341 881

MIG/MAG equipment

Assembly possibilities for wire feeders

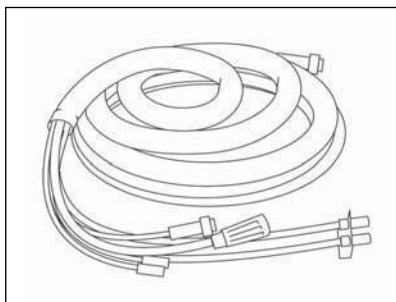

Interconnection cables

Mig 3001i, 4001i, 4002c, 5002c, 6502c (10 pole), in combination with Feed 3004/4804 (10 pole) or YardFeed 2000 (10 pole)

Length (m)	Air cooled 50 mm ²	Water cooled 50 mm ²	Air cooled 70 mm ²	Water cooled 70 mm ²	Air cooled 95 mm ²	Water cooled 95 mm ²	Connector
1.7			0459 528 780	0459 528 790	0459 528 980	0459 528 990	10/10 pole
5.0			0459 528 781	0459 528 791			10/10 pole
10.0	0459 528 562	0459 528 572	0459 528 782	0459 528 792			10/10 pole
15.0	0459 528 563	0459 528 573	0459 528 783	0459 528 793			10/10 pole
25.0*	0459 528 564	0459 528 574	0459 528 784	0459 528 794			10/10 pole
35.0*	0459 528 565	0459 528 575	0459 528 785	0459 528 795			10/10 pole
50.0*	0459 528 566	0459 528 576					

* Only for Mig 3001i/4001i in combination with Feed 3004/4804 or YardFeed 2000.

Mig 5000i, U4000i, U5000i (12 pole), in combination with Feed 3004/4804 (10 pole) or YardFeed 2000 (10 pole)

Length (m)	Air cooled 50 mm ²	Water cooled 50 mm ²	Air cooled 95 mm ²	Water cooled 95 mm ²	Connector
1.7			0459 528 970	0459 528 970	12/10 pole
5.0			0459 528 971	0459 528 971	12/10 pole
10.0	0459 528 582	0459 528 592	0459 528 972	0459 528 972	12/10 pole
15.0	0459 528 583	0459 528 593	0459 528 973	0459 528 973	12/10 pole
25.0	0459 528 584	0459 528 594	0459 528 974	0459 528 974	12/10 pole
35.0	0459 528 585	0459 528 595	0459 528 975	0459 528 975	12/10 pole
50.0	0459 528 586	0459 528 596			12/10 pole

Mig 402c, 502c, 652c (19 pole) in combination with Feed 304/484 M13 (19 pole)

Length (m)	Air cooled 50 mm ²	Water cooled 50 mm ²	Air cooled 70 mm ²	Water cooled 70 mm ²	Air cooled 95 mm ²	Water cooled 95 mm ²	Connector
1.7			0459 836 880	0459 836 890	0459 836 980	0459 836 990	19/19 pole
5.0			0459 836 881	0459 836 891			19/19 pole
10.0	0459 836 562	0459 836 572	0459 836 882	0459 836 892			19/19 pole
15.0	0459 836 563	0459 836 573	0459 836 883	0459 836 893			19/19 pole
25.0	0459 836 564	0459 836 574	0459 836 884	0459 836 894			19/19 pole
35.0	0459 836 565	0459 836 575	0459 836 885	0459 836 895			19/19 pole
50.0	0459 836 566	0459 836 576					19/19 pole

Mig 320, 410, 510 (23 pole) in combination with Feed 304/484 M11/M12 (23 pole)

Length (m)	Air cooled 70 mm ²	Water cooled 70 mm ²	Air cooled 95 mm ²	Water cooled 95 mm ²	Connector
1.7	0469 836 880	0469 836 885	0469 836 890	0469 836 895	23/23 pole
5.0	0469 836 981	0469 836 983	0469 836 982	0469 836 984	23/23 pole
10.0	0469 836 881	0469 836 886	0469 836 891	0469 836 896	23/23 pole
15.0	0469 836 882	0469 836 887	0469 836 892	0469 836 897	23/23 pole
25.0	0469 836 883	0469 836 888	0469 836 893	0469 836 898	23/23 pole
35.0	0469 836 884	0469 836 889	0469 836 894	0469 836 899	23/23 pole

Mig 320, 410, 510 (23 polig) in combination with YardFeed 200 (19 pole)

Length (m)	Air cooled 50 mm ²	Water cooled 50 mm ²	Connector
10.0	0459 836 582	0459 836 592	23/19 pole
15.0	0459 836 583	0459 836 593	23/19 pole
25.0	0459 836 584	0459 836 594	23/19 pole
35.0	0459 836 585	0459 836 595	23/19 pole
50.0	0459 836 586	0459 836 596	23/19 pole

Adapter Amphenol 10 pole – Burndy 12 pole

0349 311 510

The adapter is used inbetween cable sets with Burndy 12-pole plug, to a power source with Amphenol 10-pole plug.

Adapter Amphenol 19 pole – Burndy 23 pole

0349 311 511

The adapter is used inbetween cable sets with Burndy 23-pole plug, to a power source with Amphenol 19-pole plug.

Other equipment for MIG/MAG welding

Ordering information

1. Quick connector for MARATHON PAC™	F102 440 880
2. Spool cover plastic Aristo® Feed/Origo™ Feed	0458 674 880
3. Spool cover steel Aristo® Feed/Origo™ Feed	0459 431 880
4. Guide pin for Aristo® Feed/Origo™ Feed a	0458 731 880
Adapter for 5 kg spool for Aristo® Feed/Origo™ Feed	0455 410 001
Adapter for 440 mm spool for Aristo® Feed/Origo™ Feed	0459 233 880

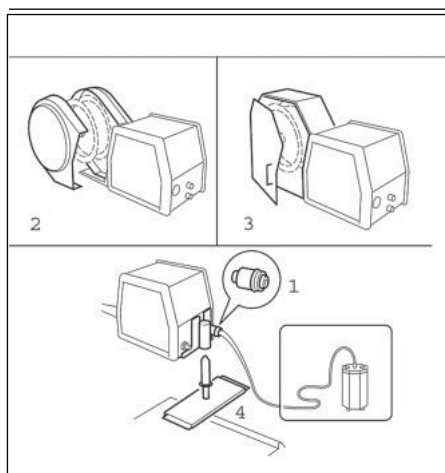

MIG/MAG equipment

Wear parts for wire feeders

Aristo® Feed 3004, Origo™ Feed 3004 and Origo™ Feed 304, Aristo® Feed L3004 and Origo™ Feed L3004, Aristo® YardFeed 2000, Origo™ YardFeed 2000 and Origo™ YardFeed 200

Wire Ø mm	Wire type	Pressure roller	Inlet nozzle	Insert tube	Outlet nozzle	Groove type	Marking
0.6 / 0.8	Fe, Ss, C	0459 052 001	0455 049 001	0455 072 002	0469 837 880	V	0.6 S2 & 0.8 S2
0.8 / 0.9-1.0	Fe, Ss, C	0459 052 002	0455 049 001	0455 072 002	0469 837 880	V	0.8 S2 & 1.0 S2*
0.9-1.0 / 1.2	Fe, Ss, C	0459 052 003	0455 049 001	0455 072 002	0469 837 880	V	1.0 S2 & 1.2 S2
1.2/1.2	Fe, Ss, C	0459 052 010	0455 049 001	0455 072 002	0469 837 880	V	1.2 S2 & 1.2 S2
1.4 / 1.6	Fe, Ss, C	0459 052 013	0459 049 001	0455 072 002	0469 837 880	V	1.4 S2 & 1.6 S2
0.9-1.0 / 1.2	C	0458 825 001	0455 049 001	0455 072 002	0469 837 880	V-K	1.0 R2 & 1.2 R2
1.2 / 1.4	C	0458 825 002	0455 049 001	0455 072 002	0469 837 880	V-K	1.2 R2 & 1.4 R2
1.6	C	0458 825 003	0459 049 001	0455 072 002	0469 837 880	V-K	1.6 R2
0.8 / 0.9-1.0	Al	0458 824 001	0455 049 001	0456 615 001	0469 837 881	U	0.8 A2 & 1.0 A2
1.0/1.2	Al	0458 824 002	0455 049 001	0456 615 001	0469 837 881	U	1.0 A2 & 1.2 A2
1.2 / 1.6	Al	0458 824 003	0455 049 001	0456 615 001	0469 837 881	U	1.2 A2 & 1.6 A2

C=cored wire. K=knurled groove

Bold = standard deliveries

* L3004/C3000i

Aristo® Feed 4804, Origo™ Feed 4804 and Origo™ Feed 484

Wire Ø mm	Wire type	Feed roller	Bogie	Outlet nozzle	Insert tube	Groove type	Bogie markings	1	2	3
0.6-1.2	Fe,Ss,C	0366 966 880	0366 902 880	0469 837 880	0156 603 001	V	1	0.6-0.8	0.9-1.0	1.2
0.9-1.6	Fe,Ss,C	0366 966 900	0366 902 900	0469 837 880	0156 603 001	V	6	0.9-1.0	1.2	1.4-1.6
1.2	Fe,Ss,C	0366 966 889	0366 902 894	0469 837 880	0156 603 001	V	7	1.2	1.2	1.2
1.4-1.6	Fe,Ss,C	0366 966 881	0366 902 881	0469 837 880	0156 603 001	V	2	1.4-1.6	2.0	2.4
2.0-2.4	Fe,Ss,C	0366 966 881	0366 902 881	0469 837 882	0156 603 002	V	2	1.4-1.6	2.0	2.4
1.2-1.6	C	0366 966 882	0366 902 882	0469 837 880	0332 322 001	V-K	3	1.2	1.4-1.6	2.0
2.0	C	0366 966 882	0366 902 882	0469 837 882	0332 322 001	V-K	3	1.2	1.4-1.6	2.0
2.4	C	0366 966 883	0366 902 883	0469 837 882	0333 322 002	V-K	4	2.4	not used	not used
1.0-1.6	Al	0366 966 899	0366 902 899	0469 837 881	0156 603 001	U	U4	1.0	1.2	1.6
1.2	Al	0366 966 885	0366 902 886	0469 837 881	0156 603 001	U	U2	1.2	1.2	1.2

C=cored wire. K=knurled groove

Bold = standard deliveries

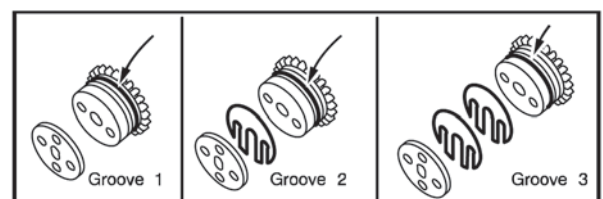

Aristo® Feed 300

Wire Ø mm	Wire type	Feed roller	Inlet nozzle	Inlet nozzle Marathon Pac	Intermediate nozzle	Outlet nozzle	Groove type
0.8	Fe, Ss, C	0460 898 881	0462 037 001	0462 037 002	0462 043 001	0469 837 880	V
0.9-1.0	Fe, Ss, C	0460 898 882	0462 037 001	0462 037 002	0462 043 001	0469 837 880	V
1.2	Fe, Ss, C	0460 898 883	0462 037 001	0462 037 002	0462 043 001	0469 837 880	V
1.4	Fe, Ss, C	0460 898 884	0462 037 001	0462 037 002	0462 043 001	0469 837 880	V
1.6	Fe, Ss, C	0460 898 885	0462 037 001	0462 037 002	0462 043 001	0469 837 880	V
2.0	C, Al	0460 898 886	0462 037 001	0462 037 002	0462 043 002	0469 837 882	V
2.4	C, Al	0460 898 887	0462 037 001	0462 037 002	0462 043 002	0469 837 882	V
1.0	Al	0462 295 882	0462 037 001	0462 037 002	0462 043 001	0469 837 881	U
1.2	Al	0462 295 883	0462 037 001	0462 037 002	0462 043 001	0469 837 881	U
1.6	Al	0462 295 885	0462 037 001	0462 037 002	0462 043 001	0469 837 881	U

C=cored wire. K=knurled groove

Bold = standard deliveries

MIG/MAG equipment



Wear parts for wire feeders

Origo™ Feed 302

Wire Ø mm	Wire type	Feed roller	Pressure roller	Inlet nozzle	Insert tube	Outlet nozzle	Groove type
0.6 / 0.8	Fe, Ss, C	0369 557 001	0369 728 001	0466 074 001	0455 889 001	0455 886 001	V
0.8 / 1.0	Fe, Ss, C	0369 557 002	0369 728 001	0466 074 001	0455 889 001	0455 886 001	V
1.0 / 1.2	Fe, Ss, C	0369 557 003	0369 728 001	0466 074 001	0455 889 001	0455 886 001	V
1.0-1.2 / 1.4-1.6	C	0369 557 004	0466 262 001	0466 074 001	0455 889 001	0455 886 001	V-K
0.8 / 0.9	Al	0369 557 011	0369 728 001	0466 074 001	0455 894 001	0455 885 001	U
1.0 / 1.2	Al	0369 557 006	0369 728 001	0466 074 001	0455 894 001	0455 885 001	U

C=cored wire. K=knurled groove

Bold = standard deliveries

Origo™ Feed L302

Wire Ø mm	Wire type	Feed roller	Pressure roller	Inlet nozzle	Insert tube	Outlet nozzle	Groove type
0.6 / 0.8	Fe, Ss, C	0367 556 001	0455 907 001	0466 074 001	0455 889 001	0455 886 001	V
0.8 / 1.0	Fe, Ss, C	0367 556 002	0455 907 001	0466 074 001	0455 889 001	0455 886 001	V
1.0 / 1.2	Fe, Ss, C	0367 556 003	0455 907 001	0466 074 001	0455 889 001	0455 886 001	V
1.0 / 1.2	Al	0367 556 004	0455 907 001	0466 074 001	0455 894 001	0455 885 001	U

C=cored wire

Bold = standard deliveries

Origo™ Feed L304

Wire Ø mm	Wire type	Feed roller	Pressure roller	Inlet nozzle	Insert tube	Outlet nozzle	Groove type
0.6 / 0.8	Fe, Ss, C	0369 557 001	0455 907 001	0455 049 001	0455 072 002	0469 837 880	V
0.8 / 1.0	Fe, Ss, C	0369 557 002	0455 907 001	0455 049 001	0455 072 002	0469 837 880	V
1.0 / 1.2	Fe, Ss, C	0369 557 003	0455 907 001	0455 049 001	0455 072 002	0469 837 880	V
1.4 / 1.6	Fe, C	0369 557 013	0455 907 001	0455 049 001	0455 072 002	0469 837 880	V
0.8 / 0.9	Al	0369 557 011	0455 907 001	0455 049 001	0456 615 001	0469 837 881	U
1.0 / 1.2	Al	0369 557 006	0455 907 001	0455 049 001	0456 615 001	0469 837 881	U

C=cored wire

Bold = standard deliveries

MIG/MAG equipment

Torches and components



MXL™ Torches

- 4 gas-cooled welding torches.
- Ergonomic handles.
- Optimum cooling of torches, extended service life for swan necks and wear parts.
- Spring-loaded contact pins in the central connector.
- Hose length 3 and 4 m.
- Gas nozzles in 3 different versions; standard, straight and conical, provide maximum flexibility and an optimum service life.

	MXL™ 150v	MXL™ 200	MXL™ 270	MXL™ 340
Max load at 35% duty cycle, A	150	200	270	340
Wire Ø, unall. solid	0.6-0.8	0.6-1.0	0.8-1.2	0.8-1.2
Wire Ø, SS	0.6-0.8	0.6-1.0	0.8-1.2	0.8-1.2
Wire Ø, Al	-	1.0	1.0-1.2	1.0-1.2
Wire Ø, CW	0.8	0.8-0.9	0.9-1.2	0.9-1.2
Weight, kg	1.1 (2.5 m)	1.6/2.0	2.2/2.6	2.6/3.7

Ordering information

MXL™ 150v, 2.5 m	0700 200 001
MXL™ 200, 3.0 m	0700 200 002
MXL™ 200, 4.0 m	0700 200 003
MXL™ 270, 3.0 m	0700 200 004
MXL™ 270, 4.0 m	0700 200 005
MXL™ 340, 3.0 m	0700 200 006
MXL™ 340, 4.0 m	0700 200 007



PSF™ self-cooled

There are four different types of self-cooled PSF™ welding torches and they can be ordered with two different hose lengths. The handles are ergonomically curved. A range of different angled swan necks provides easy access to all the different welding positions and a comfortable working position. PSF™ 405 is available with a built-in, three-step, remote-control switch (RS3).

	PSF™ 250	PSF™ 305	PSF™ 405/RS3	PSF™ 505
Max load at 60% duty cycle, A	250	315	380	475
Wire Ø, unall. solid	0.6-1.0	0.8-1.2	0.8-1.6	1.0-2.4
Wire Ø, SS	0.6-1.0	0.8-1.2	0.8-1.2	1.0-1.6
Wire Ø, Al	1.0	1.0-1.2	1.0-1.6	1.0-2.4
Wire Ø, CW	1.0	1.0-1.2	1.0-1.6	1.2-2.4

Ordering information

PSF™ 250, 3 m/4.5 m	0368 100 882/883
PSF™ 305, 3 m/4.5 m	0458 401 880/881
PSF™ 405, 3 m/4.5 m	0458 401 882/883
PSF™ 505, 3 m/4.5 m	0458 401 884/885
PSF™ 405 RS3, 4.5 m	0458 401 893

RS3 = remote control 3-steps

MIG/MAG equipment

Torches and components



PSF™ water-cooled

The water-cooled PSF™ torches are probably the coolest welding torches on the market. The excellent cooling allows for a smaller swan neck with no reduction in current capacity, plus reduced wear part consumption. A swivel at the back of the handle reduces strain on the welder's wrist. Together with the opportunity to use different angled swan necks, this provides easy access to all welding positions and a comfortable working position.

Both torches are available with a built-in, three-step, remote-control switch (RS3).

	PSF™ 410w/ 410w RS3	PSF™ 510w/ 510w RS3
Max load at 100% duty cycle, A	400	500
Wire Ø, unall. solid	0.8-1.6	1.0-2.4
Wire Ø, SS	0.8-1.6	1.0-1.6
Wire Ø, Al	1.0-1.6	1.2-2.4
Wire Ø, CW	0.9-1.6	0.9-2.0

Ordering information

PSF™ 410w, 3 m/4.5 m	0458 400 882/883
PSF™ 510w, 3 m/4.5 m	0458 400 884/885
PSF™ 410w RS3, 3 m/4.5 m	0458 400 898/899
PSF™ 510w RS3, 3 m/4.5 m	0458 400 900/901

w = water connection
RS3 = remote control 3-steps



PSF™ Centrovac self-cooled

The Centrovac welding torches have integrated smoke extraction, providing a smoke-free working environment for the welder. The handles are ergonomically designed and incorporate a reduction valve for suction adjustment. The PSF™ 250C and 315CLD have a small handle, providing easy access to all the different welding positions. PSF™ 405C has a swivel at the back of the handle to reduce the strain on the welder's wrist.

	PSF™ 250C	PSF™ 315CLD	PSF™ 405C
Max load at 60% duty cycle, A	250	315	380
Wire Ø, unall. solid	0.6-1.2	0.8-1.2	0.8-1.6
Wire Ø, SS	0.6-1.2	0.8-1.2	0.8-1.6
Wire Ø, Al	0.8-1.2	1.0-1.2	1.0-1.6
Wire Ø, CW	0.9	0.9-1.2	0.9-1.6

Ordering information

PSF™ 250C, 3 m/4.5 m	0468 410 882/883
PSF™ 315CLD, 3 m/4.5 m	0468 410 885/886
PSF™ 405C, 3 m/4.5 m	0458 499 882/883

C = smoke extraction

MIG/MAG equipment

Torches and components



PSF™ Centrovac water-cooled

The water-cooled Centrovac welding torch is probably the coolest welding torch on the market. The integrated smoke extraction provides a smoke-free working environment for the welder. Ergonomically-designed handle incorporating a reduction valve for suction adjustment. The water-cooled Centrovac torch has a swivel at the back of the handle to reduce the strain on the welder's wrist. PSF™ 410Cw RS3 has a built-in, three-step, remote-control switch.

PSF™ 410Cw/410Cw RS3

Max load at 100% duty cycle, A	380
Wire Ø, unall. solid	0.8-1.6
Wire Ø, SS	0.8-1.2
Wire Ø, Al	1.0-1.6
Wire Ø, CW	0.9-1.6

Ordering information

PSF™ 410Cw, 3 m/4.5 m
 PSF™ 410Cw RS3, 3 m/4.5 m
 C = smoke extraction
 w = water connection
 RS3 = remote control 3-steps

0458 450 880/881
 0458 450 884/885



PSF™ 315M

Welding torch for MIG/MAG welding in mechanised applications.

- Straight or precision bent 25° swan neck – easy to change gun without recalibrating.
- Liners with controlled flexibility in both steel and PTFE – for stable wire feeding.
- Connection for pneumatic spatter cleaning.
- Contact tip protrudes 3 mm to increase accessibility.
- Spatter protection – high temperature resistance and prevents welding spatter from penetrating the swan neck.

PSF™ 315M

Max load at 60% duty cycle, A	315 (CO ₂)
Max load at 60% duty cycle, A	285 (MIX)
Max load at 100% duty cycle, A	200 (CO ₂)
Max load at 100% duty cycle, A	170 (MIX)
Wire Ø, unall. solid	0.8-1.2
Wire Ø, SS	0.8-1.2
Wire Ø, Al	1.0-1.2
Wire Ø, CW	0.9-1.2

Ordering information

PSF™ 315M 1.5 m standard 25 degree
 PSF™ 315M 1.5 m straight
 PSF™ 315M 2.2 m standard 25 degree
 PSF™ 315M 2.2 m straight
 PSF™ 315M 3.0 m standard 25 degree
 PSF™ 315M 3.0 m straight
 PSF™ 315M 1.5 m extended, 25 degree

0367 233 894
 0367 233 896
 0367 233 900
 0367 233 901
 0367 233 898
 0367 233 905
 0367 233 904

MIG/MAG equipment

Torches and components



PKB™ 250/400

The pneumatic A9A is a push-pull system consisting of PKB™ 250 and 400, Origo™ FeedAirmatic wire feeder and welding hoses of different lengths and dimensions. The torch is powered by air and the feed speed is set steplessly by a knob on the torch. The trigger permits creep starts and speed reductions during welding. The hose connection supplies current, wire, shielding gas and air in the same connection.

	PKB™ 250	PKB™ 400
Pressure, bar	5	5
Wire Ø, unall. solid	0.6-1.2	0.6-1.6
Wire Ø, SS	0.6-1.2	0.6-1.6
Wire Ø, Al	0.8-1.2	0.8-1.6
Wire Ø, CW	1.0-1.2	1.0-1.6
Wire feed, m/min	0-18	0-18
Weight, kg	1.2	1.4

Ordering information

PKB™ 250 welding torch	0152 700 881
PKB™ 250 5m Torch hose assy	0460 380 880
PKB™ 250 10m Torch hose assy	0460 380 881
PKB™ 250 16m Torch hose assy	0460 380 882
PKB™ 400 welding torch	0152 470 881
PKB™ 400 5m Torch hose assy	0460 380 883
PKB™ 400 10m Torch hose assy	0460 380 884
PKB™ 400 16m Torch hose assy	0460 380 885



MXH™ 300/400w PP

MXH™ 300/400w PP are electric push-pull welding torches.

- Air- and water-cooled pistol grip torches with straight and curved 45 degree swan necks.
- Allows 360 degree rotation of the curved swan neck to suit various welding positions.
- Couples with ESAB feeding mechanisms to produce a high performance push-pull feeding system.
- Ideal for feeding aluminium and other small diameter wires long distances.
- Wire feed speed controlled by a potentiometer located on the torch handle.

	MXH™ 300 PP	MXH™ 400w PP
Wire Ø, unall. solid	0.8-1.2	0.8-1.2
Wire Ø, SS	0.8-1.2	0.8-1.2
Wire Ø, Al	0.8-1.2	0.8-1.6
Wire Ø, CW	0.9-1.2	0.9-1.2
Weight, kg	6.6/9.2	5.6/7.8

Ordering information

MXH™ 300 PP, 6.0 m	0700 200 017
MXH™ 300 PP, 10.0 m	0700 200 018
MXH™ 300 PP 45°, 10.0 m	0700 200 020
MXH™ 400 w PP, 6.0 m	0700 200 015
MXH™ 400 w PP, 10.0 m	0700 200 016
MXH™ 400w PP 45°, 10.0 m	0700 200 019
Swan neck 45° water cooled	0700 200 251
Swan neck 45° air cooled	0700 200 253
Connection kit Aristo® Feed, Origo™ Feed	0459 020 883
Connection and wire feed control kit Aristo® Feed, Origo™ Feed	0459 681 881
Connection kit Origo™ Mig C340 PRO	0349 308 980
Connection kit Origo™ Mig C420 PRO	0349 308 337
Connection and wire feed control kit Mig C3000i	0459 681 891

MIG/MAG equipment

PSF™ (MXH/PKB) wear parts/components

Type of welding torch		PSF™ 250 PSF™ 250C	PSF™ 315 CLD	PSF™ 305 PSF™ 410w PSF™ 410Cw	PSF™ 405 PSF™ 510w PSF™ 405C	PSF™ 505		
Wear parts								
Swan neck self-cooled PSF™ 250-505	Acc. 0°	0469 329 880	-	0469 333 880	0469 334 880	0469 335 880		
	Std. 45°	0366 315 880	-	0366 388 880	0366 389 880	0366 390 880		
	Acc. 60°	0467 985 880	-	0467 988 881	0467 988 880	0467 989 880		
Swan neck water-cooled PSF™ 410w-510w	Acc. 0°	-	-	0458 403 886	0458 403 887	-		
	Std. 45°	-	-	0458 403 881	0458 403 882	-		
	Acc. 60°	-	-	0458 403 884	0458 403 885	-		
Swan neck self-cooled Centrovac	Std. 45°	0366 315 880	0457 862 880	-	0459 763 880	-		
Swan neck water-cooled Centrovac	Std. 45°	-	-	0458 487 880	-	-		
Gas nozzle self-/water-cooled Threaded	Tapered	0458 465 881	0458 465 882	0458 465 882	0458 465 883	0458 465 884		
	Std.	0458 464 881	0458 464 882	0458 464 882	0458 464 883	0458 464 884		
	Straight	0458 470 881	0448 470 882	0458 470 882	0458 470 883	0458 470 884		
Spatter protection	self-/water-cooled gas nozzle	0458 471 002	0458 471 003	0458 471 003	0458 471 004	0458 471 005		
Spotwelding acc.	self- and water-cooled	0366 643 881	0366 643 882	0366 643 882	0366 643 883	0366 643 884		
Tip adaptor self-cooled	M6	0366 314 001	0366 394 001	0366 394 001 (305)	0366 394 001	-		
	M8	-	-	0366 394 002 (410w)	0366 394 002	0366 395 001		
	HELIX™ M7	0368 310 001	0368 311 001	0368 311 001	0368 311 001	0368 312 001		
	HELIX™ M8	-	-	0366 394 002	0366 394 002	0366 395 001		
Contact tip		M6 x 27 CuCrZr						
CO₂	Mix/Ar	0.6	0468 500 001	0468 500 001	0468 500 001	0468 500 001	-	
		-	0468 500 002	0468 599 002	0468 500 002	0468 500 002	-	
		0.8	0468 500 003*	0468 500 003*	0468 500 003*	0468 500 003*	-	
		0.9	0468 500 004*	0468 500 004	0468 500 004	0468 500 004	-	
		1.0	0468 500 005*	0468 500 005*	0468 500 005*	0468 500 005*	-	
		1.2	0468 500 007*	0468 500 007*	0468 500 007* (305)	0468 500 007*	-	
		1.4	-	0468 500 008	0468 500 008*	0468 500 008*	-	
		1.6	-	-	0468 500 009	0468 500 009	-	
		-	-	-	0468 500 010	0468 500 010	-	
		1.6	-	-	-	-	-	
		1.6	-	-	-	-	-	
Contact tip		M8 x 37 CuCrZr						
CO₂	Mix/Ar	0.8	-	-	0468 502 003*	0468 502 003*	0468 502 003*	
		0.9	-	-	0468 502 004*	0468 502 004	0468 502 004	
		1.0	-	-	0468 502 005*	0468 502 005*	0468 502 005*	
		1.2	-	-	0468 502 007* (410w/CW)	0468 502 007* (405/405C)	0468 502 007*	
		1.4	-	-	0468 502 008*	0468 502 008*	0468 502 008*	
		1.6	-	-	0468 502 009	0468 502 009 (510w)	0468 502 009	
		-	-	-	0468 502 010	0468 502 010	0468 502 010	
		2.0	-	-	-	0468 502 011 (510w)	0468 502 011	
		2.4	-	-	-	0468 502 012 (510w)	0468 502 012	
		Contact tip	Please see main brochure or HELIX™ and Nib.					
		Liner Steel liner for non- alloyed and cored wires.		3 m/4.5 m	3 m/4.5 m	3 m/4.5 m	3 m/4.5 m	3 m/4.5 m
0.6 - 0.8	0366 549 882/883		0366 549 882/883	0366 549 882/883	0366 549 882/883	-		
0.9 - 1.0	0366 549 884/885		0366 549 884/885	0366 549 884/885	0366 549 884/885	0366 549 884/885		
1.2	0366 549 886/887		0366 549 886/887	0366 549 886/887	0366 549 886/887 (405/405C)	0366 549 886/887		
1.4	-		-	0366 549 888/889	0366 549 888/889	0366 549 888/889		
1.6	-		-	0366 549 890/891	0366 549 890/891 (510w)	0366 549 890/891		
2.0	-		-	-	0366 549 898 (4.5 m – 510w)	0366 549 898 (4.5 m)		
2.4	-	-	-	0366 549 899 (4.5 m – 510w)	-			
Liner PTFE liner for Fe, Ss, Al	0.6	0366 550 880/881	0366 550 880/881	-	-	-		
	0.8	-	0366 550 882/883	0366 550 882/883	0366 550 882/883	-		
	0.9 - 1.0	-	0366 550 884/885	0366 550 884/885	0366 550 884/885	0366 550 884/885		
	1.2	-	0366 550 886/887	0366 550 886/887	0366 550 886/887	0366 550 886/887		
	1.4	-	-	0366 550 888/889	0366 550 888/889	0366 550 888/889		
	1.6	-	-	0366 550 890/891	0366 550 890/891	0366 550 890/891		
	2.0/2.4	-	-	-	0366 550 892/893 (510w)	0366 550 892/893		
PTFE liner beige Full length without wear insert	1.0-1.2	0457 969 882/883	0457 969 882/883	0457 969 882/883	0457 969 882/883	0457 969 882/883		
	1.4-1.6	-	-	0457 969 884	0457 969 884	0457 969 884		

* Articles marked with * available in 100-pack. Only change position seven in the article number. Ex. 0468 500 003 become 0468 500 303.

Bold = standard deliveries

MIG/MAG equipment

MXL™ wear parts/components

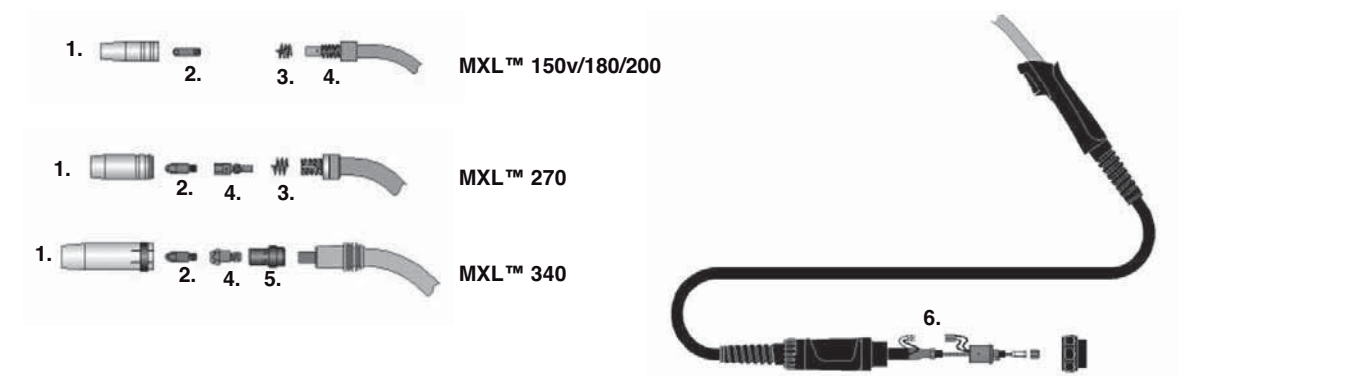

1.	MXL™ 150v	MXL™ 180	MXL™ 200	MXL™ 270	MXL™ 340
Gas nozzle standard Ø12 mm	0700 200 054	0700 200 054	0700 200 054		
Gas nozzle standard Ø15 mm				0700 200 055	
Gas nozzle standard Ø16 mm					0700 200 056
Gas nozzle straight Ø16 mm	0700 200 057	0700 200 057	0700 200 057		
Gas nozzle straight Ø18 mm				0700 200 058	
Gas nozzle straight Ø19 mm					0700 200 059
Gas nozzle conical Ø 9.5 mm	0700 200 060	0700 200 060	0700 200 060		
Gas nozzle conical Ø11.5 mm				0700 200 061	
Gas nozzle conical Ø12 mm					0700 200 062
2.					
Contact tip Cu W0.6 M6	0700 200 063	0700 200 063	0700 200 063		
Contact tip Cu W0.8 M6	0700 200 064	0700 200 064	0700 200 064		
Contact tip Cu W0.9 M6	0700 200 065	0700 200 065	0700 200 065		
Contact tip Cu W1.0 M6	0700 200 066	0700 200 066	0700 200 066		
Contact tip Cu W0.8 M6				0700 200 068	0700 200 068
Contact tip Cu W0.9 M6				0700 200 069	0700 200 069
Contact tip Cu W1.0 M6				0700 200 070	0700 200 070
Contact tip Cu W1.2 M6				0700 200 071	0700 200 071
3.					
Nozzle spring	0700 200 078	0700 200 078	0700 200 078		
Nozzle spring				0700 200 079	
4.					
Tip adaptor M6 MXL™ 150v	0700 200 076				
Tip adaptor M6 MXL™ 200		0700 200 072	0700 200 072		
Tip adaptor M6 MXL™ 270				0700 200 073	
Tip adaptor M6-Alu MXL™ 270				0700 200 067	
Tip adaptor M6, short MXL™ 340					0700 200 074
Tip adaptor M6, long MXL™ 340					0700 200 075
5.					
Gas diffusor					0700 200 080
6.					
Steel liner W0.6 - W0.8 2.5 m	0700 200 099				
Steel liner W0.6 - W0.8 3.0 m		0700 200 085	0700 200 085	0700 200 085	0700 200 085
Steel liner W0.6 - W0.8 4.0 m			0700 200 086	0700 200 086	0700 200 086
Steel liner W0.9 - W1.2 3.0 m		0700 200 087	0700 200 087	0700 200 087	0700 200 087
Steel liner W0.9 - W1.2 4.0 m			0700 200 088	0700 200 088	0700 200 088
PTFE liner W0.6 - W0.8 3.0 m		0700 200 089	0700 200 089	0700 200 089	0700 200 089
PTFE liner W0.6 - W0.8 4.0 m			0700 200 090	0700 200 090	0700 200 090
PTFE liner W0.9 - W1.2 3.0 m		0700 200 091	0700 200 091	0700 200 091	0700 200 091
PTFE liner W0.9 - W1.2 4.0 m			0700 200 092	0700 200 092	0700 200 092

Bold = standard deliveries

Ancillary equipment

Remote controls

Recommendation table – combinations of remote controls, power sources and feeders.

	Con- nector type	MTA 1 CAN	M1 10P CAN	AT1 CAN	AT1 CF CAN	M1	AT1	AT1 CF	RA 12	RA 23	RA T1	FS 002	T1 Foot CAN	MIG 2	MMA 1	MMA 2	NO2
Caddy® Tig 2200i AC/DC	A	X	X	X	X						X		X				
Origo™ Tig 3001i	B	X	X	X	X						X		X				
Origo™ Tig 3000i AC/DC	A	X	X	X	X						X		X				
Origo™ Tig 4300iw AC/DC	A	X	X	X	X						X		X				
Caddy® Tig 1500i/2200i, TA34	A	X	X	X	X						X		X				
Origo™ Arc 410c/650c/810c	C						X	X							X	X	X
Caddy® Arc 251i	C						X	X				X			X	X	
Caddy® Arc 151i/201i, A33	C						X	X				X			X	X	
Origo™ Feed, M12	D					X								X			
Origo™ Feed, M13	D					X								X			
Origo™ Feed, MA23/24	B	X	X														
Origo™ Mig C3000i, MA23/23A	A	X	X	X	X					X							
Aristo® Mig C3000i, U6	A	X	X	X	X				X	X							
Aristo® Feed, U6/U8 ₂	B	X	X	X	X				X	X	X		X				
Origo™ Arc, A22/A24	B	X	-/X	X	X				X								
Origo™ Mig, A24	B	X	X	X	X				X								
Aristo® Tig 4000i, TA4	A	X		X	X				X		X		X				
Aristo® Tig 4000i, TA6	A	X	X	X	X				X		X		X				

Interconnection cables

Length	Type A: CAN 12p	Type B: CAN 10 p	Type C: Analogue 12 p	Type D: Analogue 23p
0.25 m	0459 554 884	0459 960 883	–	–
5 m	0459 554 880	0459 960 880	0459 552 880	0459 553 880
10 m	0459 554 881	0459 960 881	0459 552 881	0459 553 881
15 m	0459 554 882	–	0459 552 882	–
25 m	0459 554 883	0459 960 882	0459 552 883	–
5 m HD	0459 554 980	0459 960 980	–	–
10 m HD	0459 554 981	0459 960 981	–	–
25 m HD	–	0459 960 982	–	–



AT1 CAN

CAN based standard remote control for MMA and TIG. Suitable for control panel A22, A24, A44, TA4, TA6, TA23, TA24, TA23 AC/DC, TA24 AC/DC, TA34, TA33 AC/DC, TA34 AC/DC. MMA/TIG: Current control.

Ordering information

AT1 CAN 0459 491 883



AT1 CoarseFine CAN

CAN based standard remote control for MMA and TIG. Suitable for control panel A22, A24, A44, TA4, TA6, TA23, TA24, TA23 AC/DC, TA24 AC/DC, TA34, TA33 AC/DC, TA34 AC/DC. MMA/TIG: Current control, coarse/fine.

Ordering information

AT1 CoarseFine CAN 0459 491 884



MTA1 CAN

CAN based multi function remote control for the control panels A22, A24, A44, TA4, TA6, TA23, TA24, MA23, MA23A, MA24, MA43, MA44, U6 and Aristo® U8₂. MMA: Knob 1, Current control. Knob 2, Arc force. TIG: Knob 1, Pulse current. Knob 2,

Background current.
MIG/MAG 1: Knob, wire feed speed.
Knob 2, voltage control.
MIG/MAG 2: Knob, wire feed speed.
Knob 2, voltage trim +/-.

Ordering information

MTA1 CAN 0459 491 880

Ancillary equipment

Remote controls



M1 10Prog CAN

CAN based remote control for control panel A24, A44, MA23, MA23A, MA24, MA43, MA44, U6, U8₂, TA24, TA24 AC/DC, TA34 and TA34 AC/DC.

MIG/MAG: Memory 1-10 and voltage trim +/-
TIG/MMA: Memory 1-10 and current trim +/-
Pulse TIG: Memory 1-10 and pulse current trim +/-

Ordering information

M1 10Prog CAN 0459 491 882

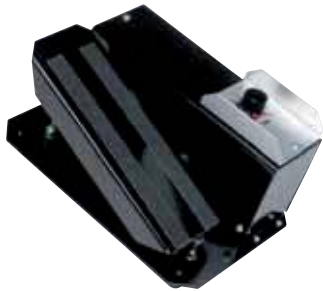

FS 002

Foot pedal for starting and stopping as well as for stepless current setting. Max. current can also be set using a potentiometer. Used mostly for TIG welding.

Ordering information

FS 002 with 5 m cable, 12 p, (Type C) 0349 090 886



T1 Foot CAN

Foot pedal for starting and stopping as well as for stepless current setting. Used mostly for TIG welding.

Ordering information

T1 Foot CAN with 5 m cable, 12 p, (Type A) 0460 315 880
Extension cable 5 m, 12 p 0459 554 886
T1 Foot CAN with 5 m cable, 10 p, (Type B) 0460 315 881



AT1

Analogue standard remote control for MMA and TIG. Suitable for power sources with remote outlet. MMA/TIG: Current control.

Ordering information

AT1 0459 491 896



AT1 CoarseFine

Analogue standard remote control for MMA and TIG. Suitable for power sources with remote outlet. MMA/TIG: Current control, coarse/fine.

Ordering information

AT1 CoarseFine 0459 491 897



M1

Analogue standard remote control. Suitable for MIG for control panel M10, M12 and M13. MIG/MAG: Wire feed and voltage control

Ordering information

M1 0459 491 895

Ancillary equipment

Remote controls



Remote control MMA 1

The remote control MMA 1 is equipped with one knob, giving the welder the opportunity to steplessly adjust the current. It comes with a 10-metre rubber cable with a 12-pole plug (Type C) and a metal hook for easy handling when not welding.

Ordering information

Remote-control MMA 1, 12 p, (Type C)

0349 501 024



Remote control MMA 2

The remote control MMA 2 is equipped with two knobs, giving the welder the opportunity to make both rough and fine current settings. It comes with a 10-metre rubber cable with a 12-pole plug (Type C) and a metal hook for easy handling when not welding.

Ordering information

Remote-control MMA 2, 12 p, (Type C)

0349 501 025



Remote control MIG 2

The remote control MIG 2 is equipped with a 23-pole plug (Type D) and is suitable for MIG/MAG machines. With this remote, it is possible to set both wire feed speed and voltage. It comes with a five-metre rubber cable and a metal hook for easy handling when not welding.

Ordering information

Remote-control MIG 2, 23 p, (Type D)

0349 501 028



Transmitter NO2

Transmitter NO2 is an alternative, wireless remote control system for Arc 410c/650c/810c, A12 and LHF 405/615 PIPEWELD welders.

Ordering information

Remote control NO2

0349 304 617



Remote Adapter 12

Remote adapter for CAN based systems. For analogue MMA and TIG remote controls.

Ordering information

RA 12 for MMA and TIG

0459 491 910



Remote Adapter 23

Remote adapter for CAN based systems. For analogue MIG/MAG remote controls and 3-step program switch RS3.

Ordering information

RA 23 for MIG/MAG and RS3

0459 491 911

Ancillary equipment

Trolleys



1

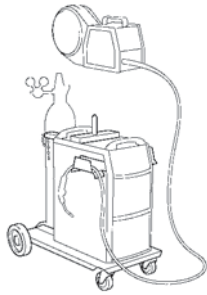

2

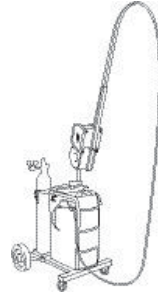

3



4



5



6



7



8



9



10



11



12

Ordering information

	Caddy®/ Origo™ Arc 150i/200i Caddy®/ Origo™ Tig 150i/200i	Aristo® MechTig 4000iw	Aristo® MechTig 3000i	Aristo® MechTig C2002i	Aristo® Arc Origo™ Arc 4000i/5000i	Aristo® Mig 4000i/ 5000i	Aristo® Tig 4000i Origo™ Tig 4300iw AC/ DC	Origo™ Mig C3000i/ L3000i	Aristo® Mig C3000i/ L3000i	Origo™ Tig 3000i Origo™ Tig 3000i AC/ DC	Caddy® Arc 151i/201i/251i Caddy® Tig 1500i/2200i Caddy™ Tig 2200i AC/DC	Mig 3001i, Arc 4001i, Mig 4001i	Mig 3001i, Mig 4001i, Tig 3001i	Aristo® 300/ 400/500	Caddy® Mig C160i/ C200i
1. 0301 100 880				•											
2. 0458 530 880						•									
3. 0458 603 880						•									
4. 0458 530 881		•					•								
5. 0459 366 885	•										•	*	*		
6. 0459 366 886	•				•						•				
7. 0459 366 890			•					•	•	•		*	*		
8. 0460 060 880			•					•	•	•		*	*		
9. 0460 330 880											•				
10. 0460 564 880**												•			
11. 0460 565 880													•		
12. 0459 366 887															•

• = Recommended solution

* = Alternative solution. Only without water cooler.

** = Feeder platform 0460 815 880 not included

Quick guide

Control panel functions



M11/M12

- Adjustable burn-back timer
- Creep start
- 2/4 stroke
- Wire feed speed
1.9-20 m/min (M11)
1.9–25 m/min (M12)



MA23

- CC/CV
- Digital V/A meter
- 3 memories
- 2/4 stroke
- Step-less inductance setting
- Gas purge and wire inching
- Remote control



M13

- Additional functions to M12
- Crater filling
 - Voltage setting

M13 V/A

- Additional functions to M13
- * Digital V/A meter



MA24

- MMA and MIG/MAG
- Synergic MIG/MAG
- QSet™
- Creep start
- Crater fill
- 2/4 stroke
- Panel or Remote operation
- Gas purge and wire inching
- Digital V/A meter
- Stepless inductance setting
- 3 memories



A13

- MIG/MAG- All functions controlled from the feeder panel
- MMA
- Air Carbon Arc Gouging
- TIG
- Digital V/A meter



A32

- MMA or TIG (with LiveTig™ start)
- Remote control (analogue) or panel choice
- Digital display
- Current setting



A22

- MMA or TIG (LiveTig™ start)
- Current
- Digital V/A-meter
- Panel or Remote operation
- VRD indicator



A33

- MMA or TIG (with LiveTig™ start)
- Remote control function (analogue)
- Current setting
- Adjustable Hot start
- Adjustable Arc force
- Two memory positions
- Digital display



A24

- MMA, MIG/MAG (CV-mode) or TIG (LiveTIG start)
- Electrode type
- Current
- Digital V/A meter
- Hot start MMA
- Arc Force
- Stepless Inductance (CV-mode)
- Two memories
- Panel or Remote operation
- VRD indicator



A34

- MMA or TIG (with LiveTig™ start)
- Current setting
- Electrode type selection
- Remote control (analogue) or panel choice
- Adjustable Hot start
- Adjustable Arc force
- Two memory positions
- Digital display



TA4

- TIG/MMA
- MMA arc force, hot start
- Gas pre/post flow
- Slope up/down
- HF/Lift Arc
- 2/4 stroke
- Display measurement V/A



TA23

- Slope up
- Welding current
- Slope down
- Gas post flow time
- Welding method TIG/MMA
- HF/LiftArc start
- 2/4 stroke
- Panel/remote control
- Digital display

Quick guide

Control panel functions



TA24

- Additional functions to TA23:
- Pulse TIG (DC)
 - Pulse current
 - Pulse time
 - Background current
 - Background time
 - 2 memory positions



TA33 AC/DC

- Digital display
- Welding method TIG/MMA
- Welding processes
- TIG: AC/DC-
- MMA: DC/DC-/AC
- HF/LiftArc start
- 2/4 stroke
- Panel/remote
- Plate thickness setting
- Slope down
- Gas postflow time



TA24 AC/DC

- Additional functions to TA24:
- AC TIG welding
 - AC balance
 - AC frequency
 - Electrode preheating



TA34 AC/DC

- Welding method TIG/ Pulse TIG/MMA
- Welding processes
- TIG: AC/DC-/DC Pulse
- MMA: DC/DC-/AC
- HF/LiftArc start
- 2/4 stroke
- Panel/remote/memory selection
- 2 memory positions
- Slope up/down
- Welding current
- Pulse time
- Background current and time
- Gas post flow time
- AC balance and frequency
- Electrode preheating



U6

- Additional functions to TA6:
- MIG/MAG
 - Voltage
 - Wire feed speed
 - Burnback timer
 - Inductance, stepless
 - Crater filling
 - Creep start
 - Synergic MIG/MAG
 - Synergic pulse MIG
 - Hot start MIG
 - Wire inching
 - QSet™



Aristo® U8₂

Aristo® U8₂ is a complete, fully equipped programming unit as well as a user friendly control pendant for Feed 3004/4804.



TA6

- Additional functions to TA4:
- MMA: electrode type
 - Gas purge
 - Pulse TIG (DC)
 - 10 memory positions
 - Multi language



MA43

- MIG/MAG and MMA
- 2/4 stroke
- Stepless inductance setting
- Gas purge/wire inching
- Digital meter
- 3 memories
- Panel or Remote operation



TA33

- Digital display
- Welding method TIG/MMA
- HF/LiftArc™ start
- 2/4 stroke
- Plate thickness setting
- Slope down
- Gas postflow time



MA44

- MIG/MAG and MMA
- Synergic MIG/MAG
- QSet™
- Creep start
- Crater fill
- 2/4 stroke
- Stepless inductance setting
- Gas purge/wire inching
- Digital meter
- 3 memories
- Panel or Remote operation



TA34

- Additional functions to TA33 (Plate thickness setting not included)
- Welding method TIG/ Pulse TIG/MMA
 - Panel/remote/memory selection
 - 2 memory positions
 - Welding current
 - Pulse time
 - Background current
 - Background time
 - Slope up/down
 - Gas postflow time



A44

- MMA (CC), MIG/MAG (CV) or TIG (LiveTig™ start)
- Electrode type
- Current
- Hot Start / Arc Force (MMA)
- Stepless Inductance (CV)
- Digital meter
- 2 memories
- Panel or Remote operation
- VRD indicator

Ancillary equipment

Cooling units



CoolMini

Cooling unit suitable for TIG torches. Working together with Tig 2200i and 2200i AC/DC.

CoolMini

Mains supply, V/Hz from power source	230, 1~ 50/60
Cooling water, l/min	2
Coolant volume, l	2.2
Cooling capacity, W/l/min	700/1.0
Max water pressure, bar	2.3
External dimensions, LxWxH, mm	407x187x137
Weight, kg	4.5/6.7

Ordering information

Cooling unit, CoolMini	0460 144 880
ESAB coolant 10 l.	0007 810 012
Connection kit for Caddy® Tig 2200i machines	0460 509 880



CoolMidi 1000

Cooling unit suitable for MIG/MAG and TIG torches. Working together with Mig 3001i, Origo™ Mig 3001i, Mig 4001i, Origo™ Mig 4001i and Origo™ Tig 3001i.

CoolMidi 1000

Mains supply, V/Hz from power source	400, 3~ 50/60
Cooling water, l/min	4.0
Coolant volume, l	5.0
Cooling capacity w/l/min	1100/1.0
Max water pressure 50/60 Hz, bar	3/3.8
External dimensions, LxWxH, mm	690x245x300
Weight, kg	14/19

Ordering information

CoolMidi 1000	0460 490 880
ESAB coolant, 10 l	0007 810 012
Connection kit for 3001i machines	0460 685 880

Ancillary equipment

Cooling units



CoolMidi 1800

Cooling unit suitable for MIG and TIG torches. Working together with Tig 3000i, Tig 3000i AC/DC, Mig L3000i and Mig C3000i. Connection cable (12-12 pole) included.

CoolMidi 1800

Mains supply, V/Hz	400, 3~50/60
Cooling water, l/min	4
Cooling capacity, W/l/min	1700
Coolant volume, l	4.2
Max water pressure 50/60 Hz, bar	3/3.8
External dimensions, LxWxH, mm	710x385x208
Weight, kg	19/23

Ordering information

CoolMidi 1800	0459 840 880
ESAB coolant 10 l.	0007 810 012

Ancillary equipment

Cooling units



OCE-2 H

The OCE-2 H water-cooling unit is an efficient, compactly-dimensioned cooling unit designed for use together with water-cooled equipment for arc welding by hand or in automatic plants. The water tank and pump are made of stainless corrosion-resistant material.



OCE-2 H

Mains supply, V/Hz	230/50-60
Cooling water, l/min	5.5
Coolant volume, l	8
Cooling capacity, W/l/min	2000
Max water pressure, bar	3.3
External dimensions, LxWxH, mm	316x236x374
Weight, kg	14/21

Ordering information

OCE-2 H	0414 191 881
Flow guard to OCE-2 H	0414 231 880
ESAB coolant 10 l.	0007 810 012



Multi Voltage units

Autotransformer TUA 1 and TUA 2 are two autotransformers which can be used together with most of the ESAB welding power sources. The autotransformer is available in two versions: TUA 1 narrow and TUA 2 wide.

Ordering information

Multi Voltage unit TUA 1	0459 144 880
Handle incl. mounting screws for separate installation (Complete set = 2)	0459 307 880
Multi Voltage unit TUA 2	0459 145 880
Handle incl. mounting screws for separate installation (Complete set = 2)	0459 307 881



FeedSelector

FeedSelector is a switch unit for connecting two wire feeders to one welding rectifier. Can be used when welding with two different electrode wires and one or two shielding gases are required. The FeedSelector switches the welding current and the required control circuits between the wire feeders. FeedSelector is an excellent partner for Origo™ Mig 400t/tw, 500t/tw, 630t/tw, 410/w, 510/w, 402c/cw, 502c/cw, 652c/cw.

Delivery includes:

FeedSelector, assembly elements, instruction manual.

FeedSelector

Mains supply, V/Hz	42, 50/60
Max output at 35% duty cycle, A	630
Max output at 60% duty cycle, A	500
Max output at 100% duty cycle, A	400
Weight, kg	34

Ordering information

FeedSelector (Origo™ Mig 400t/tw, 500t/tw, 630t/tw, 410/w, 510/w)	0349 308 248
FeedSelector (Origo™ Mig 402c/cw, 502c/cw, 652c/cw)	0349 311 680

Manual plasma cutting equipment

Plasma cutting packages



Origo™ Cut 36i

Origo™ Cut 36i is a small and portable, single phase 230 V/ 17A, plasma cutting package. Perfect for repair and maintenance. Cuts all metals, including copper and aluminium. Mild steels up to 12 mm can be separated. Few settings makes it easy to use. Just add electricity and compressed air. The powerful HF start goes straight through a drawing, placed or glued on top of the plate – cuts the exact part you need. Full Compliance with Harmonics Regulations IEC61000-3-12(2006-08)

Delivery includes

Origo™ Cut 36i, 4.5 m PT 31XL torch, 5 m return lead, 2.5 m mains cable with Schuko plug, carrying strap and wear part kit



Origo™ Cut 36i

Mains supply, V/Hz	230, 50/60
Fuse, slow, A	17
Max output at 35% duty cycle, A/V	35/94
Max output at 60% duty cycle, A/V	27/91
Max output at 100% duty cycle, A/V	21/88
Setting range, A	15-35
Open circuit voltage, V	270
Air, l/min	118
Pressure, bar	5.2
Cutting capacity, Fe mm	6/8
Cutting capacity, SS mm	6/8
Cutting capacity, Al mm	6/8
Weight, kg	9.5

Ordering information

Origo™ Cut 36i, CE, 4.5 m torch, 1ph 230 V

0558 007 873

Manual plasma cutting equipment

Plasma cutting packages



Manual plasma cutting equipment

Plasma cutting packages



ESP 150

This heavy-duty, water-cooled plasma cutting and gouging system provides the perfect solution for production cutting and plasma gouging.

The ESP 150 can cut up to 51 mm manually and can sever 63 mm, using either an Ar/H₂ mixture or compressed air. Gas options for higher quality cuts, especially on aluminium and stainless, resulting in lower total operating costs – the PT 26 torch cuts with nitrogen or argon-hydrogen mixtures; choice of carbon dioxide, air, nitrogen or oxygen for torch cooling.

Delivery includes

The ESP 150 package includes a 7.6 m leather protected PT 26 torch, torch wear part kit, 7.6 m work cable, dual cylinder rack/wheel kit, regulators/filters, torch hooks, torch coolant and gas hose.



ESP 150

Mains supply, V/Hz	400/50
Fuse, slow, A	70
Mains cable, Ø mm ²	4x25
Max load at 100% duty cycle, A	140
Setting range, A	50-150
Open circuit voltage, V	370
Air, l/min	113/95/95
Pressure, bar	7/7/7
Cutting capacity, Fe mm	40/50
Cutting capacity, SS mm	25/38
Cutting capacity, Al mm	40/50
Weight, kg	308

Ordering information

ESP 150, CE, 7.5 m torch, 400 V	0558 003 472
Optional accessories:	
Torch PT 26, 70°, 15 m	0558 002 209
Torch PT 26, INLINE, mech, 7.6 m	0558 002 320
Torch PT 26, INLINE, mech, 15 m	0558 002 321
Remote hand switch	0558 003 796
Leather protection for torch hose 7.6 m	0558 002 921
Leather protection for torch hose 15 m	0558 002 922

Manual plasma cutting equipment



Plasma torches



Plasma gouging

Plasma gouging is an effective way of removing material, when preparing for the next layer to be welded or for removing faults. Generally speaking, the advantages of using plasma instead of carbon rods are 50% less noise, 50% fewer particles in the air, 50% less energy consumed, no carbon deposits in the material and the fact that gouging can be performed on all materials (even high-alloyed

and aluminium).

Only two parts need to be changed (no tools needed) to gouge instead of cut – the nozzle and an additional metal gouging heat shield.

Ordering information

Gouging nozzle, PT 26	0558 003 718
Close proximity shield, PT 26	0558 003 715
Gouging nozzle, PT 38 60A	0558 008 588
Gouging shield, PT 38 60A	0558 008 591
Gouging nozzle, PT 38 90A	0558 007 681
Gouging shield, PT 38 90A	0558 008 186



Wear part kits

These wear part kits organize your plasma cutting wear parts for more efficient handling.

Includes: electrodes, swirl baffle, nozzles, heat shield etc.

Ordering information

Wear parts kit, PT 26	0558 002 864
Wear parts kit, PT 31XL, 35A	0558 003 462
Wear parts kit, PT 31XL, 50A	0558 003 464
Wear parts kit PT38, 60A	0558 003 419
Wear parts kit PT38, 90A	0558 007 640



Torch guide kits

The deluxe guide kit can be used for straight line, circular (45 to 1050 mm) or bevel plate edge preparations. Position using pin on rivot mark, magnet or suction cup. The same kit can be used for torches PT 17, 23, 25, 27, 31XL, 32EH, 34 and 38. A basic kit for plasma cutting torches PT 17, 23, 25, 27, 31XL, 32EH, 34 and 38 with circular guide (45 to 750 mm) using pin on rivot mark is also available.

Ordering information

Deluxe cutting guide kit, PT 17, 23, 25, 27, 31XL, 32EH, 34 and 38	0558 003 258
Basic circle guide kit, PT 23, 27, 31XL, 32EH, 34 and 38	0558 002 675



PT 26

This versatile, easy-to-use, 300 Amp, water-cooled plasma cutting torch provides superior performance for a full range of manual and mechanised cutting. Available in a manual version and a mechanised version (IN-LINE). Used on ESP 150.

Ordering information

PT 26, 70°, 7.6 m	0558 002 208
PT 26, 70°, 15 m	0558 002 209
PT 26, IN-LINE, 7.6 m	0558 002 320
PT 26, IN-LINE, 15 m	0558 002 321
Electrode, air N, N/H	0558 003 722
Electrode Ar/H (H35)	0558 003 723
Nozzle, 150 A, w O-ring	0558 003 717
Nozzle, gouging, with O-ring	0558 003 718
Heat shield	0558 003 714
Stand-off guide	0558 003 713
Remote hand switch	0558 003 796
Baffle tube with O-rings	0558 003 708
Insulator with O-rings	0558 003 711
Torch head with O-rings PT 26	0558 003 719

PT 31XL

The PT 31XL is the smallest 50 A plasma cutting torch on the market. Designed for superior operator comfort. Rated at 50 A in continuous operation. Specially designed to make it easy to access places that are difficult to reach. For drag cutting with HF starts.

PT31XL is used on CaddyCut, Handy-Plasma 50 and PCM 500i.

PT31XLPC is a PT31XL with torch connections for PC650.

Ordering information

Heat shield	0558 000 509
Nozzle, 35/40 A	0558 000 508
Swirl baffle	0558 000 506
Electrode	0558 000 507
Plunger	0558 000 511
Replaceable seat	0558 000 510
Torch body	0558 000 790
Nozzle, 50 A	0558 000 513
PT 31XL, 4.5 m torch	0558 001 466
PT 31XL, 7.6 m torch	0558 000 690
PT 31XLPC, 7.6 m torch	0558 005 393



Manual plasma cutting equipment

Plasma torches



PT 37

The PT37 is a mechanized torch for use with PC900 and PC1600

Ordering information

PT-37 Torch with rack 7.6m.	0558004862
PT-37 Torch without rack 5.2m	0558004895
Plug N Play Mechanized kit	0558007885
Remote Hand Switch , 7,6m lead	0558008349



PT 38

The PT38 has an ergonomic handle for operator comfort with big face switch maximizes convenience when wearing welder's gloves.

Low operating costs since it is easily repairable in the field with minimum part configurations and moulded strain relief for secure torch leads. PT38 is used on PC900 and PC1600

Ordering information

PT 38, 7.6 m	0558 006 786
PT 38, 15 m	0558 006 787
Nozzle, 90 A	0558 007 680
Nozzle, 60 A	0558 008 417
Nozzle, 40 A drag	0558 007 682
Nozzle gouging 90A	0558 007 681
Nozzle gouging 60A	0558 008 588
Electrode	0558 005 220
Insulator PC900	0558 005 217
Insulator PC1600	0558 004 870
Heat shield, CE	0558 008 094
Heat shield gouging 90A	0558 008 186
Heat shield gouging 60A	0558 008 591
Stand off guide 90A	0558 006 614
Stand off guide 60A	0558 008 592
PT 38 Torch head	0558 006 789
O-ring lubricant	0558 000 443



***ESAB Welding Automation
for quality, productivity, working environment***

Orbital TIG welding

Welding heads orbital TIG



Introduction Orbital TIG

New and improved metal qualities, rising material and labour costs, but also more sensitive materials, and continuously increasing demands on quality and productivity are factors which you have to deal with daily.

ESAB helps you to get ahead and stay ahead. Our metallurgists, chemists, engineers, technicians and skilled welders have one dedication: to find better materials and develop better equipment for your welding.

The ESAB welding program for mechanised tube welding is based on the TIG welding method with a non-consumable tungsten electrode.

To further improve weld quality and decrease costs, ESAB have developed micro-processor controlled power sources for orbital TIG welding, the Aristo® MechTig C2002i, MechTig 3000i and MechTig 4000iw with control boxes Aristo® MechControl 2 and 4. A21 is ESAB's welding head for tube-to-tube welding, A22 is a welding head for tube-to-tube sheet welding and A25 is a modular component system for orbital TIG welding.

If you need other equipment than what is shown in the catalogue, please contact your nearest ESAB representative.

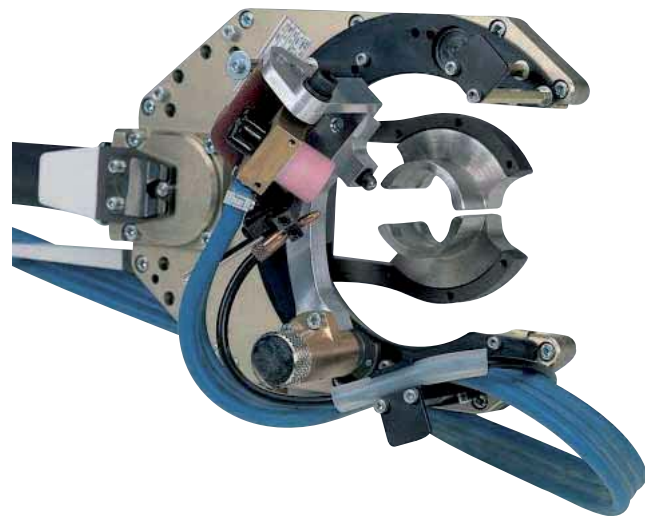

A21 PRB

The PRB welding head is compact and easy to use as a result of its unique pincer action which reduces setting-up times to a minimum. The welding head is positioned and secured around the tube with great accuracy in seconds. The PRB welding heads are available in three sizes for tubes with outer diameters of 17 to 170 mm.

Use these welding heads together with the Aristo® MechTig power sources.

Delivery includes

7 m of connection cable (current, gas, water).

	PRB 17-49	PRB 33-90	PRB 60-170
Rate of rotation, rpm	0.1-2.4	0.1-1.6	0.05-0.95
Tube diameters OD, mm	17-49	33-90	60-170
Max welding current, water, A	250	250	250
Max welding current, air, A	100	100	100
Electrode diameter, mm	1.6, 2.4	2.4, 1.6	2.4, 1.6
Weight, kg			

Ordering information

PRB 17-49, water-cooled	0443 750 882
PRB 17-49, air-cooled	0443 750 883
PRB 33-90, water-cooled	0443 760 882
PRB 33-90, air-cooled	0443 760 883
PRB 60-170, water-cooled	0443 770 882
PRB 60-170, air-cooled	0443 770 883

Accessories for PRB:

Rebuilding kit for PRB/PRC 17-49 for welding tubes with outside diameters from 8-17 mm	0444 002 880
Rebuilding kit PRB/PRC 33-90 for welding tubes with outside diameters from 20-33 mm	0443 908 880
Rebuilding kit PRB/PRC 60-170 for welding tubes with outside diameters from 44-60 mm	0443 909 880
Wire holder complete with gas lense diameter 24 mm with adjustable wire nozzle for PRB/PRC 33-170	0443 923 880

Orbital TIG welding

Welding heads orbital TIG

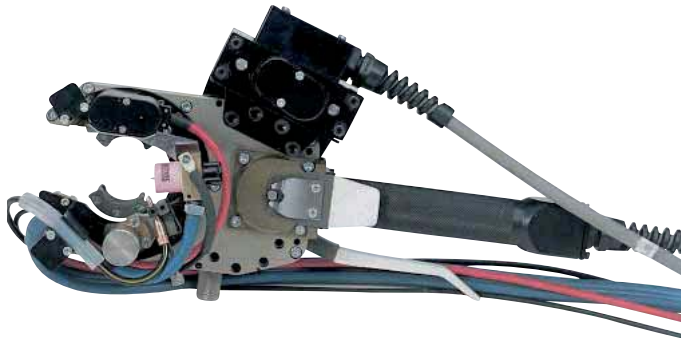

A21 PRC

The PRC welding head is a further development of our PRB welding head. The PRC features a zig-zag weaving movement and arc voltage control, which produces higher productivity and better welding quality, particularly when welding thick-walled tubes. These welding heads are used together with the Aristo® MechTig power sources.

Delivery includes

7 m of connection cable (current, gas, water).

	PRC 17-49	PRC 33-90	PRC 60-170
Rate of rotation, rpm	0.1-2.4	0.1-1.6	0.05-0.95
Tube diameters OD, mm	17-49	33-90	60-170
Max welding current, A			
Weaving range, mm	20	20	20
Weaving reach, mm	7	7	7
Weaving speed, mm/s	1.0-12	1.0-12	1.0-12
Dwell time, s	0.1-10	0.1-10	0.1-10
Arc setting speed, mm/s	1.1	1.1	1.1
Weight, kg			

Ordering information

PRC 17-49 with AVC	0443 751 881
PRC 17-49 with AVC and weaving	0443 752 881
PRC 33-90 with AVC	0443 761 881
PRC 33-90 with AVC and weaving	0443 762 881
PRC 60-170 with AVC	0443 771 881
PRC 60-170 with AVC and weaving	0443 772 881

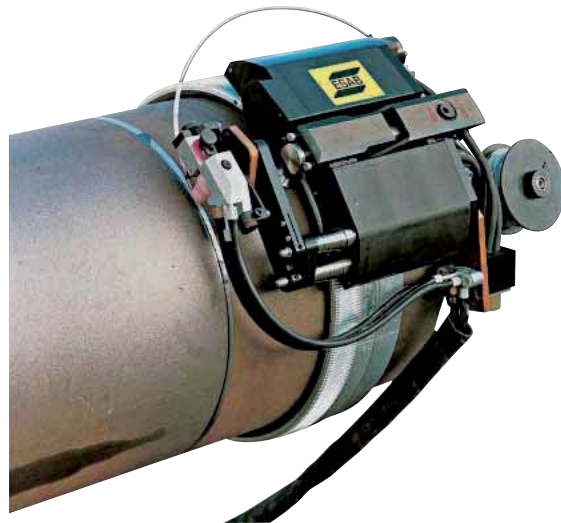

A21 PRD 100

The PRD 100 welding head is designed for precision, quality and technology of the highest class. It is a TIG welding head for tubes with an outer diameter of 100 mm and upwards. The PRD 100 is very compact in design and, as a result of its low profile, requires only 73 mm of clearance around the tube. The welding head is water-cooled and designed for amperage of up to 400 A. The mechanical settings are easy, all the welding parameters are incorporated in the procedure program which are controlled by a microprocessor system. Use this welding head together with the Aristo® MechTig power sources.

Delivery includes

8 m of connection cable (current, gas, water) and motor cable.

	PRD 100
Rotation speed, cm/min	2-40
Tube diameters OD, mm	100 to flat
Electrode diameter, mm	1.0-4.0
Max welding current, A	400 (pulsed DC)
Weaving range, mm	+/-15
Weaving speed, mm/s	1-10
Dwell time, s	0.1-10
Arc voltage control amplitude, mm	25
Arc setting speed, mm/s	2.0
Weight, kg	8

Ordering information

PRD 100 welding head	0444 016 880
Racks and accessories see page 69	

Orbital TIG welding

Welding heads orbital TIG

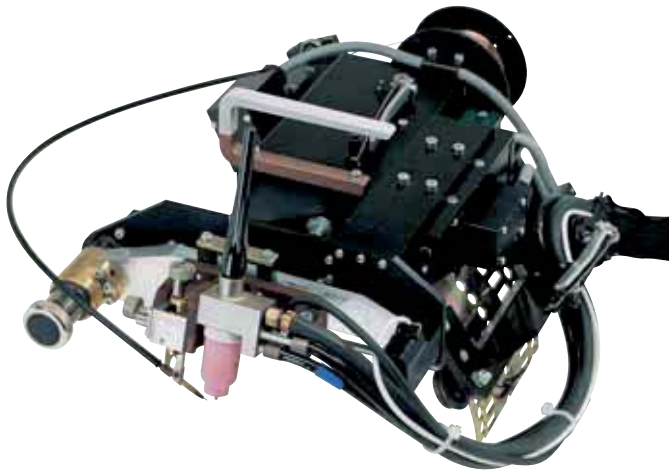

A21 PRD 160

The PRD 160 is a water-cooled flexible pipe-welding head, for pipes with an outer diameter of 160 mm and upwards. The PRD consists of an articulated carriage that travels around the pipe on a rack that is adapted to match the diameter of the pipe. To ensure maximum flexibility, the welding head is built in modules. The basic unit, for thin-walled pipes, includes only one motor, for travel. Depending on the application, it is possible to add wire-feed-, arc voltage control- and weaving-modules for the thicker wall applications. PRD 160 can be used together with the Aristo® MechTig power sources.

Delivery includes

8 m of connection cable (current, gas, water) and motor cable.

PRD 160	
Rotation speed, cm/min	2-40
Tube diameters OD, mm	160-1025
Electrode diameter, mm	1.6-3.2
Max welding current, A	400 (pulsed DC)
Weaving range, mm	+/-15
Weaving speed, mm/s	2-12
Dwell time, s	0.1-10
Weight, kg	8

Ordering information

Basic unit intended only for fusion welding with a floating head	0444 151 880
Basic unit with wire feeder unit complete	0444 151 881
Basic unit with AVC (Arc Voltage Control)	0444 151 882
Basic unit with AVC plus wire feeder unit complete	0444 151 883
Basic unit with AVC plus wire feeder unit complete and weave unit	0444 151 884
Wire feeder unit complete	0444 137 880
AVC (Arc Voltage Control) complete	0443 656 881
Weave unit complete	0444 140 880
Racks and accessories, see page 69	



A21 PRH

ESAB's PRH tube-welding tool is designed for welding thin-walled, stainless steel tubes in order to provide maximum gas shielding around the tube. The tool has been designed according to the chamber principle to produce this shield. This means that the rotating part and the Tungsten electrodes are enclosed in a gas chamber formed by the outer casing, which also constitutes the clamping arrangement for the tube to be welded. The tube-welding tool is water-cooled and forms a complete unit which also incorporates the return conductor. It is available in three sizes, PRH 3-12, PRH 3-38 and PRH 6-76, making it possible to weld tubes of between 3 mm and 76.2 mm.

All three heads are equipped with encoder motors for precise positioning of each sector when welding with different sets of parameters.

Delivery includes

8 m of connection cable (current, gas, water and return).

	PRH 3-12	PRH 3-38	PRH 6-76
Max output at 100% duty cycle, A	15	50	60
Rate of rotation, rpm	0.65-12.6	0.5-9.5	0.31-6.15
Tube diameters OD, mm	3-12.7	3-38.1	6-76.2
Max welding current, water, A	40	100	100
	(pulsed)	(pulsed)	(pulsed)
Electrode diameter, mm	1.0	1.6/2.4	1.6/2.4
Weight, kg	5.0	6.5	7.5

Ordering information

Welding head PRH 3-12	0444 300 880
Welding head PRH 3-38	0444 301 880
Welding head PRH 6-76	0444 302 880
Cartridges and collets are available for all diameters within the working range for each tool. Standard sizes, see page 70	

Orbital TIG welding

Welding heads orbital TIG



A22 POC

The POC 12-60 is a welding head for tube-to-tube sheet TIG welding. It is a precision-built, robust and versatile welding head which can be used for all types of tube-to-tube-sheet welding. The POC has a working range of 12 to 60 (93) mm outer tube diameter. The centering accuracy of the POC is very high and centering mandrels are available for inner tube diameters from 10.0 mm.

POC can be used together with the Aristo® MechTig power sources.

Delivery includes

8 m of connection cable (current, gas, water).

POC

Rate of rotation, rpm	0.2-4.5
Working range, electrode parallel to tube axis, mm	12-60
Working range, electrode at 30° from tube axis, mm	12-36 (93)
Filler wire diameter, mm	0.8-0.9
Filler wire speed, mm/s	0.15-1.5
Max spool dimension/weight, Ø mm/kg	100/0.5
Weight, kg	4.8 (without cable)

Ordering information

POC 12-60 welding head 0443 930 880

Mandrels and accessories, see page 71



Orbital TIG welding

A25 modular components

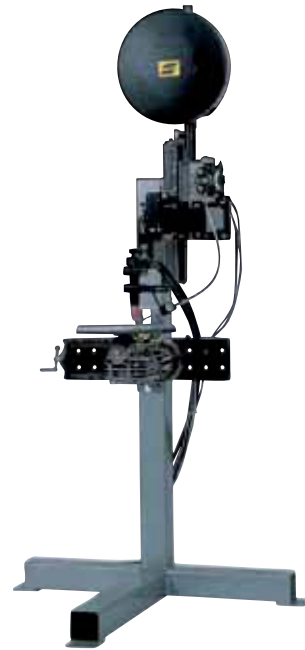

A25

A25 is a modular component system – the key to TIG welding mechanisation. The modular components can easily be put together to create a system to suit your requirements. The TIG-narrow gap method can also be used together with the A25 system. Narrow gap with an extremely small joint angle and resulting in low joint volume.

The A25 modular system is used together with the Aristo® MechTig power sources.

	A25
AVC slide amplitude, mm	76
AVC slide speed, mm/s	2.81
Weaving slide amplitude, mm	76
Weaving slide speed, mm/s	19
Manual slide amplitude, mm	93
Floating slide amplitude, mm	76
Wire diameter, mm	0.6-1.6
Wire feed, m/min	0.1-2.6
Motor VEC with encoder, speed, rpm	1000
Motor VEC with encoder, ratio	672:1

Wire capacity as standard:

A25 with BTE 250M 0.6-1.2 mm,

A25 with BTE 500M 0.6-0.8, 1.2-1.6 mm

Ordering information

A25 welding automat with AVC and weaving slides, wire feed unit, VEC motor with turntable and BTE 250M torch mounted on a stand	0443 910 880
A25 welding automat with AVC and weaving slides, wire feed unit, VEC motor with turntable and BTE 500M torch mounted on a stand	0443 910 881
A25 welding automat with AVC and BTE 250M torch	0443 911 880
A25 welding automat with AVC and BTE 500M torch	0443 911 881
A25 welding automat with AVC and weaving slides, BTE 250M torch	0443 911 882
A25 welding automat with AVC and weaving slides, BTE 500M torch	0443 911 883
A25 welding automat with AVC and manual horizontal slide, BTE 250M torch	0443 911 884
A25 welding automat with AVC and manual horizontal slide, BTE 500M torch	0443 911 885
A25 welding automat with manual vertical and horizontal slide, BTE 250M torch	0443 911 886
A25 welding automat with manual vertical and horizontal slide, BTE 500 M torch	0443 911 887
A25 welding automat with slides for floating head, BTE 250M torch	0443 912 880
A25 welding automat with slides for floating head, BTE 500M torch	0443 912 881
Railbound carriage with a 2 m track for fitting A25 welding heads	0458 002 880
PAL 3 connection box for external motor regulator	0457 870 880

Components and accessories, see page 71

Orbital TIG welding

Accessories

Standard racks for PRD 100

A specific size of rack is used for each pipe diameter. The standard racks are listed under ordering information. Individual requirements relating to racks for other diameters can be supplied to order within the working range of the PRD welding head.

Ordering information

Outer diameter of the pipe:

114.30 mm – 4 inch	0333 400 880
141.30 mm – 5 inch	0333 400 881
168.27 mm – 6 inch	0333 400 882
219.07 mm – 8 inch	0333 400 883
273.05 mm – 10 inch	0333 400 884
323.85 mm – 12 inch	0333 400 885
355.60 mm – 14 inch	0333 400 886
406.40 mm – 16 inch	0333 400 887
457.20 mm – 18 inch	0333 400 888
508.00 mm – 20 inch	0333 400 889
558.80 mm – 22 inch	0333 400 890
609.60 mm – 24 inch	0333 400 891
660.00 mm – 26 inch	0333 400 892
711.00 mm – 28 inch	0333 400 893
762.00 mm – 30 inch	0333 400 894
813.00 mm – 32 inch	0333 400 895

864.00 mm – 34 inch	0333 400 896
914.00 mm – 36 inch	0333 400 897
Straight rack with suction feet, 2 m	0334 150 880
Straight rack with suction feet, 4 m	0334 150 881
Suction pump for rack	0334 504 001
Locking screw for standard racks together with feet 0333 402 880	0212 204 306
Locking screw for standard racks together with feet 0333 402 882-885	0190 507 451
Locking screw for standard racks together with feet 0333 402 886-890	0212 204 352

Feet for standard racks with tube diameters minus ...

4 mm	0333 402 881
8 mm	0333 402 882
12 mm	0333 402 883
16 mm	0333 402 884
20 mm	0333 402 885
24 mm	0333 402 886
28 mm	0333 402 887
32 mm	0333 402 888
36 mm	0333 402 889
40 mm	0333 402 890

Standard racks for PRD 160

Ordering information

Outer diameter of the pipe:

161-177 mm	0444 063 880
185-201 mm	0444 063 881
209-225 mm	0444 063 882
225-241 mm	0444 063 883
249-265 mm	0444 063 884
265-281 mm	0444 063 885
289-305 mm	0444 063 886
313-329 mm	0444 063 887
329-345 mm	0444 063 888
345-361 mm	0444 063 889
361-377 mm	0444 063 890
385-401 mm	0444 063 891
401-417 mm	0444 063 892
425-441 mm	0444 063 893
449-465 mm	0444 063 894
473-489 mm	0444 063 895
497-513 mm	0444 063 896
513-529 mm	0444 063 897
537-553 mm	0444 063 898
553-569 mm	0444 063 899

577-593 mm	0444 063 900
601-617 mm	0444 063 901
625-641 mm	0444 063 902
649-665 mm	0444 063 903
665-681 mm	0444 063 904
689-705 mm	0444 063 905
705-721 mm	0444 063 906
729-745 mm	0444 063 907
753-769 mm	0444 063 908
777-793 mm	0444 063 909
801-817 mm	0444 063 910
817-833 mm	0444 063 911
841-857 mm	0444 063 912
857-873 mm	0444 063 913
881-897 mm	0444 063 914
905-921 mm	0444 063 915
929-945 mm	0444 063 916
953-969 mm	0444 063 917
969-985 mm	0444 063 918
993-1009 mm	0444 063 919
1009-1025 mm	0444 063 920

Other diameters are available upon request.

Orbital TIG welding

Accessories

Collets and cartridges

Ordering information

PRH 3-12

Cartridges

Cartridge C	0444 310 880
Cartridge MF 6.0 mm	0444 310 881
Cartridge MF 6.35 mm	0444 310 882
Cartridge MF 8.0 mm	0444 310 883
Cartridge MF 9.53 mm	0444 310 884
Cartridge MF 10.0 mm	0444 310 885
Cartridge MF 12.0 mm	0444 310 886
Cartridge MF 12.70 mm	0444 310 887

Collets for Cartridge C, one set, four halves

Collets C blanks	0444 311 001
Collets C 6.0 mm	0444 311 002
Collets C 6.35 mm	0444 311 003
Collets C 8.0 mm	0444 311 004
Collets C 9.53 mm	0444 311 005
Collets C 10.0 mm	0444 311 006
Collets C 12.0 mm	0444 311 007
Collets C 12.70 mm	0444 311 008

PRH 3-38

Collets, one set, four halves

Collets PRH 3-38, blanks	0444 312 001
Collets PRH 3-38 6.0 mm	0444 312 002
Collets PRH 3-38 6.35 mm	0444 312 003
Collets PRH 3-38 8.0 mm	0444 312 004
Collets PRH 3-38 9.53 mm	0444 312 005
Collets PRH 3-38 10.0 mm	0444 312 006
Collets PRH 3-38 12.0 mm	0444 312 007
Collets PRH 3-38 12.70 mm	0444 312 008
Collets PRH 3-38 13.50 mm	0444 312 009
Collets PRH 3-38 15.0 mm	0444 312 024
Collets PRH 3-38 17.20 mm	0444 312 010
Collets PRH 3-38 18.0 mm	0444 312 011
Collets PRH 3-38 19.05 mm	0444 312 012
Collets PRH 3-38 21.30 mm	0444 312 013
Collets PRH 3-38 22.0 mm	0444 312 014
Collets PRH 3-38 25.40 mm	0444 312 015
Collets PRH 3-38 26.90 mm	0444 312 016
Collets PRH 3-38 28.0 mm	0444 312 017
Collets PRH 3-38 29.0 mm	0444 312 018
Collets PRH 3-38 31.80 mm	0444 312 019
Collets PRH 3-38 33.70 mm	0444 312 020
Collets PRH 3-38 34.0 mm	0444 312 021
Collets PRH 3-38 35.0 mm	0444 312 022
Collets PRH 3-38 38.10 mm	0444 312 023

PRH 6-76

Collets, one set, four halves

Collets PRH 6-76 blanks	0444 313 001
Collets PRH 6-76 6.0 mm	0444 313 002
Collets PRH 6-76 6.35 mm	0444 313 003
Collets PRH 6-76 8.0 mm	0444 313 004
Collets PRH 6-76 9.53 mm	0444 313 005
Collets PRH 6-76 10.0 mm	0444 313 006
Collets PRH 6-76 12.0 mm	0444 313 007
Collets PRH 6-76 12.70 mm	0444 313 008
Collets PRH 6-76 13.50 mm	0444 313 009
Collets PRH 6-76 16.0 mm	0444 313 038
Collets PRH 6-76 17.20 mm	0444 313 010
Collets PRH 6-76 18.0 mm	0444 313 011
Collets PRH 6-76 19.05 mm	0444 313 012
Collets PRH 6-76 20.0 mm	0444 313 042
Collets PRH 6-76 21.30 mm	0444 313 013
Collets PRH 6-76 22.0 mm	0444 313 014
Collets PRH 6-76 25.0 mm	0444 313 039
Collets PRH 6-76 25.40 mm	0444 313 015
Collets PRH 6-76 26.40 mm	0444 313 041
Collets PRH 6-76 26.90 mm	0444 313 016
Collets PRH 6-76 28.0 mm	0444 313 017
Collets PRH 6-76 29.0 mm	0444 313 018
Collets PRH 6-76 31.80 mm	0444 313 019
Collets PRH 6-76 33.70 mm	0444 313 020
Collets PRH 6-76 34.0 mm	0444 313 021
Collets PRH 6-76 35.0 mm	0444 313 022
Collets PRH 6-76 38.10 mm	0444 313 023
Collets PRH 6-76 40.0 mm	0444 313 024
Collets PRH 6-76 41.0 mm	0444 313 025
Collets PRH 6-76 42.40 mm	0444 313 026
Collets PRH 6-76 48.30 mm	0444 313 027
Collets PRH 6-76 50.80 mm	0444 313 028
Collets PRH 6-76 51.0 mm	0444 313 040
Collets PRH 6-76 52.0 mm	0444 313 029
Collets PRH 6-76 53.0 mm	0444 313 030
Collets PRH 6-76 54.0 mm	0444 313 037
Collets PRH 6-76 60.3 mm	0444 313 031
Collets PRH 6-76 63.0 mm	0444 313 036
Collets PRH 6-76 63.50 mm	0444 313 032
Collets PRH 6-76 70.0 mm	0444 313 033
Collets PRH 6-76 76.10 mm	0444 313 034
Collets PRH 6-76 76.20 mm	0444 313 035

Orbital TIG welding

Accessories

A25 components and accessories

Ordering information

Bracket	0441 404 880	Circular slide	0145 945 880
Wire feed unit, incl feed roller, 0.6-0.8 mm	0441 300 882	Slide manual, setting range 90 mm	0413 518 880
Feed roller 1.0 – 1.2 mm	0369 557 003	Slide weaving, setting range 76 mm	0443 913 881
Feed roller 1.2 – 1.6 mm	0369 557 007	Slide floating, setting range 76 mm	0441 674 881
Outlet pipe 0.8 – 1.2 mm	0441 456 881	Single guide wheel unit, BTE 250M	0441 833 880
Outlet pipe 1.6 mm	0441 456 882	Single guide wheel unit, BTE 500M	0441 833 881
Connection cable, feed unit 10 m	0456 904 880	Bracket	0441 412 880
Wire hose, per metre (std 400 mm)	0192 799 112	Brake hub	0146 967 881
Wire nozzle, BTE 250M	0441 407 880	Bobbin protection	0157 482 880
Wire nozzle, BTE 500M	0441 407 881	Motor VEC with tachometer, speed 1000 rpm, ratio 672:1	0457 258 880
TIG torch BTE 250M, 4.0 m	0444 295 880	Control unit to VEC	0457 222 880
TIG torch BTE 500M, 4.0 m	0444 296 880	Turntable with return cable connection for VEC motor	0442 712 880
Holder BTE 250M	0441 414 880	Narrow Gap kit for BTE 500M	0441 667 880
Holder BTE 500M	0441 414 881		
Slide AVC, setting range 76 mm	0443 913 880		

POC shafts and centering mandrels

Ordering information

Shaft type A

Centering mandrel Ø 10.0 – 10.5 mm	0332 207 880	Centering mandrel Ø 26.5 – 29.0 mm	0444 542 882
Centering mandrel Ø 10.5 – 11.0 mm	0444 540 880	Centering mandrel Ø 28.5 – 31.0 mm	0444 542 883
Centering mandrel Ø 11.0 – 11.5 mm	0444 540 881	Centering mandrel Ø 30.5 – 33.0 mm	0444 542 884
Centering mandrel Ø 11.5 – 12.0 mm	0444 540 882	Centering mandrel Ø 32.5 – 36.0 mm	0444 542 885
Centering mandrel Ø 12.0 – 12.5 mm	0444 540 883	Centering mandrel Ø 35.5 – 39.0 mm	0444 542 886
Centering mandrel Ø 12.5 – 13.0 mm	0444 540 884	Centering mandrel Ø 38.5 – 42.0 mm	0444 542 887
	0444 540 885	Centering mandrel Ø 41.5 – 45.0 mm	0444 543 880
		Centering mandrel Ø 44.5 – 48.0 mm	0444 543 881
		Centering mandrel Ø 47.5 – 51.0 mm	0444 543 882

Shaft type B

Centering mandrel Ø 12.8 – 14.0 mm	0332 208 880		
Centering mandrel Ø 13.8 – 15.0 mm	0444 541 880		
Centering mandrel Ø 14.8 – 16.0 mm	0444 541 881		
Centering mandrel Ø 15.8 – 17.0 mm	0444 541 882		
Centering mandrel Ø 16.8 – 18.0 mm	0444 541 883		
Centering mandrel Ø 17.8 – 19.0 mm	0444 541 884		
Centering mandrel Ø 18.8 – 20.5 mm	0444 541 885		
Centering mandrel Ø 19.8 – 22.5 mm	0444 541 886		
	0444 541 887		

Shaft type C

Centering mandrel Ø 22.0 – 25.0 mm	0332 209 880		
Centering mandrel Ø 24.5 – 27.0 mm	0444 542 880		
	0444 542 881		

Shaft type D

Centering mandrel Ø 50.5 – 54.0 mm	0332 210 880		
Centering mandrel Ø 53.5 – 58.0 mm	0444 543 883		
Centering mandrel Ø 57.5 – 62.0 mm	0444 543 884		
Centering mandrel Ø 61.5 – 66.0 mm	0444 543 885		
Centering mandrel Ø 65.5 – 70.0 mm	0444 543 886		
Centering mandrel Ø 69.5 – 74.0 mm	0444 543 887		
Centering mandrel Ø 73.5 – 78.0 mm	0444 543 888		
Centering mandrel Ø 77.5 – 82.0 mm	0444 543 889		

POC 12-60 accessories

Ordering information

Counterbalancing block	0332 330 005
Three-point support complete with electrode holder. To be used for fillet weld up to Ø 36 mm	0333 897 880
Three-point support complete with electrode holder. To be used for fillet weld from Ø 36 mm to Ø 93 mm	0333 897 883
Front casting, titanium	0441 000 880
Internal bore welding torch 9.5-15	0441 131 880
Internal bore welding torch 15-20	0441 132 880
Internal bore welding torch 20-30	0441 133 880

Orbital TIG welding

Accessories

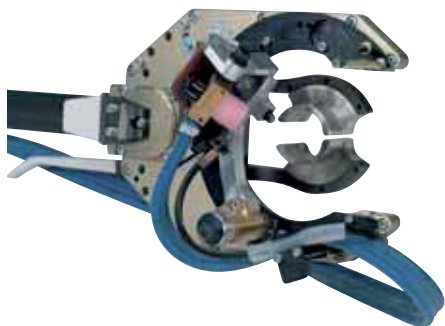

Angular support

The angular support is used to adjust the electrode angle in the joint. The support is available for PRB/PRC 17-49, 33-90 and 60-170.

Ordering information

Angular support

0443 875 880

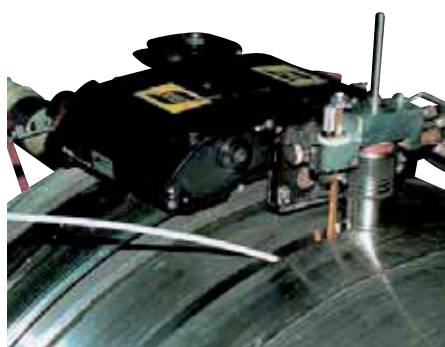

Narrow gap head for PRD

ESAB have developed equipment for Narrow Gap welding together with the PRD welding head. The TIG Narrow Gap Orbital Welding has an extremely narrow groove with a subsequent small joint volume. Welding in all positions is possible. Stainless and carbon steel can be welded.

Ordering information

Narrow Gap head 50 mm, PRD 100

0441 623 880

Narrow Gap head 80 mm, PRD 100

0441 623 881

Narrow Gap head 50 mm, PRD 160

0444 339 880

Wire straightener Ø 0.8 mm

0441 355 882

Wire straightener Ø 1.2 mm

0441 355 880



Balancing block

The balancing block is capable of carrying welding heads, drilling and grinding machines weighing 5.5-9 kg. The wire can be extended to a maximum length of 2.7 metre. The spring force is constant, i.e. the wire has the same lifting capacity irrespective of the length to which it has been extended.

Ordering information

Balancing block

0332 330 005



Remote control MechT 1 CAN

MechT 1 CAN is a small remote control that is easy to use and can control most of the parameters on Aristo® MechControl 2 and 4 and Aristo® MechTig C2002i.

The cable between the control unit and remote control is available in different lengths.

Ordering information

Remote control MechT 1 CAN

0460 181 880

Cable, length 5 m

0459 554 880

Cable, length 10 m

0459 554 881

Cable, length 15 m

0459 554 882

Cable, length 25 m

0459 554 883

Cable, length 0.25 m

0459 554 884

Orbital TIG welding

Ancillary equipment



MEI 21 wire feed unit

The MEI 21 is a wire feed unit with four wheel drive for orbital TIG welding. A separate wire feed unit is a great advantage since it eliminates the need for a wire feed unit and wire spool mounted on the welding head. 5 kg wire spools can be used. The MEI 21 can be used for wire dimensions from 0.6 mm to 0.8 mm and can be used together with the Aristo® MechTig power sources.

Delivery includes

The MEI 21 wire feed unit is delivered with a wire hose.

	MEI 21
Wire diameter, mm	0.6-0.8
Wire feed, m/min	0.1-2.6
Max spool dimension/weight, Ø mm/kg	200/5
Hub width, mm	60
Hub hole diameter, mm	51.5
Wire guide length, m	4.2
Weight, kg	4

Ordering information

MEI 21 0443 830 880

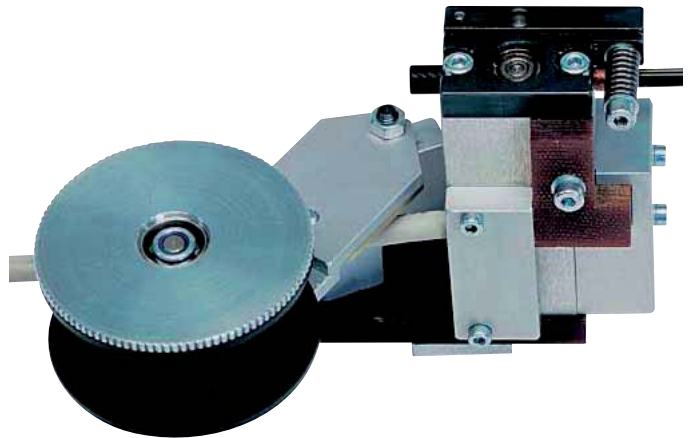

MEI 10 wire feed unit

The MEI 10 is a wire feed unit developed for mounting on PRB/PRC 17-170 tools (PRC 17-49 only with AVC). PRB/PRC tools with MEI 10 can be used together with the Aristo® MechTig power sources.

The increase in size of the tool when it is mounted, is kept to a minimum due to the compact design of the wire feed unit. Thanks to the very short distance the wire needs to be fed, from the reel to the molten pool, the MEI 10 is ideal for aluminium welding. It is naturally also possible to use the wire-feed unit for mild and stainless steel welding.

The MEI 10 weighs only 0.5 kg (without bobbin and cable) and it can be used for wire dimensions of 0.8 mm to 1.0 mm for aluminium and 0.8 mm for steel. A geared DC motor drives the feed roller via gear wheels. The motor is equipped with a pulse generator which enables the precise adjustment of the wire feed speed.

	MEI 10
Wire diameter, mm	0.8 (steel)
Wire feed, m/min	0.1-1.2
Max spool dimension/weight, Ø mm/kg	60/0.26
Wire guide length, m	0.1
Weight, kg	0.5 (excl bobbin)

Ordering information

MEI 10 for PRB 17-49 & PRC 17-49 with AVC 0444 211 880
 MEI 10 for PRB 33-90, PRC 33-90 with AVC & PRC with AVC and weaving 0444 212 880
 MEI 10 for PRB 60-170, PRC 60-170 with AVC & PRC 60-170 with AVC and weaving 0444 213 880
 Bobbin (empty) 0444 192 001

Orbital TIG welding

Power sources orbital TIG



Aristo[®] MechTig C2002i

Aristo[®] MechTig C2002i is a small and compact orbital welding power source with integrated water cooler which together with the excellent tube welding heads provides high quality and productivity. The machine is equipped with a 10 inch colour monitor and the interface is windows like. For control of the welding settings you can either use a graphical interface to control all necessary parameters or a spread sheet where you can see all parameters. The Aristo[®] MechTig C2002i is delivered with a ready library where you can find a number of pre-defined programs that you can use for fast and easy set-up. There is also a function for auto generation of programs. This function creates a start program, the only thing you need to do is to key in some basic parameters as material, outer diameter and the thickness of the pipe. The welding program can then be stored in the program library. Aristo[®] MechTig C2002i can be used together with the welding heads PRB, PRD 160 with wire feed unit, PRH, POC, wire feed units MEI 10, MEI 21 and A25 component system with manual/floating slides.

Aristo[™] MechTig C2002i

Mains supply, V/Hz	230/1 50/60
Setting range TIG, A	5-200
Open circuit voltage, V	92
Fuse (slow), A	16
Max output at 35% duty cycle, A/V	180 / 17
Max output at 60% duty cycle, A/V	140 / 16
Max output at 100% duty cycle, A/V	110 / 14
External dimensions, LxWxH	470x479x472
Weight, kg	30

Ordering information

Aristo [®] MechTig C2002i	0444 700 880
Accessories:	
Trolley	0301 100 880
Remote control MechT 1 CAN	0460 181 880
Cable between MechTig C2002i and MechT 1 CAN:	
Length 5 m	0459 554 880
Length 10 m	0459 554 881
Length 15 m	0459 554 882
Length 25 m	0459 554 883
Length 0.25 m	0459 554 884



Aristo[®] MechControl 2 and 4

Aristo[®] MechControl 2 and 4 is a small and compact orbital welding control box that together with a MechTig power source will provide high quality and productivity together with the excellent tube welding heads. The machine is equipped with a 10 inch colour monitor and the interface is windows like. For control of the welding settings you can either use a graphical interface to control all necessary parameters or a spread sheet where you can see all parameters. The Aristo[®] MechControl 2 and 4 are delivered with a ready library where you can find a number of pre-defined programs that you can use for fast and easy set-up. There is also a function for auto generation of programs. This function creates a start program, the only thing you need to do is to key in some basic parameters as material, outer diameter and the thickness of the pipe. The welding program can then be stored in the program library. Aristo[®] MechControl 2 can use the same tools as Aristo[®] MechTig C2002i, i.e. welding heads PRB, PRD 160 with wire feed unit, PRH, POC, wire feed units MEI 10, MEI 21 and A25 component system with manual/floating slides. Aristo[®] MechControl 4 can use all the tools that we have in our program.

Aristo[®] MechControl 2 and 4

Mains supply, V/Hz	42, 50/60
External dimensions, LxWxH, mm	471x403x364
Weight, kg	17.4 (MechControl 2)
Weight, kg	18.4 (MechControl 4)

Ordering information

Aristo [®] MechControl 2	0444 500 880
Aristo [®] MechControl 4	0444 500 881
Accessories:	
Connection cable 1.7 m	0460 210 880
Connection cable 8.0 m	0460 210 881
Remote control MechT 1 CAN	0460 181 880
Cable between MechControl 2 or 4 and MechT 1 CAN:	
Length 5 m	0459 554 880
Length 10 m	0459 554 881
Length 15 m	0459 554 882
Length 25 m	0459 554 883
Length 0.25 m	0459 554 884

Orbital TIG welding

Power sources orbital TIG



Aristo® MechTig 3000i

Aristo® MechTig 3000i is the ideal partner together with Aristo MechControl 2 or 4 when it comes to efficient production and prefabrication of high alloyed and low alloyed materials with a very high demand on the welding performance.

Aristo® MechTig 3000i	
Mains supply, V/Hz	3x400, 50/60
Open circuit voltage, V	57-67
External dimensions, LxWxH, mm	652x249x423
Weight, kg	30

Ordering information

Aristo® MechTig 3000i	0459 745 882
Accessories:	
CoolMidi 1800 MechTig	0459 840 881
Trolley 2-wheel	0459 366 890
Trolley 4-wheel	0460 060 880
Connection cable, 1.7 m	0460 210 880
Connection cable, 8.0 m	0460 210 881
Delivery includes 5 m mains cable incl plug and 5 m return cable incl earth clamp.	



Aristo® MechTig 4000iw

The Aristo® MechTig 4000iw is designed to work together with the Aristo® MechControl 2 and 4. The power source is compact and sturdy and based on inverter technology that provides reliable equipment with outstanding welding characteristics.

Connection cables up to 8 meters provides a working range of up to 16 meters to suit all your individual welding needs.

Aristo™ MechTig 4000iw	
Mains supply, V/Hz	3x400, 50/60
Setting range TIG DC, A	4-400
Open circuit voltage, V	78-90
Fuse (slow), A	16
Max output at 35% duty cycle, A / V	400 / 26
Max output at 60% duty cycle, A / V	320 / 23
Max output at 100% duty cycle, A / V	250 / 20
Power factor at maximum current	0.75
Efficiency at maximum current, %	97.1
External dimensions (with cooling unit), LxWxH	625x394x776
Weight, kg	81

Ordering information

Aristo® MechTig 4000iw	0458 625 886
Accessories	
Multi voltage unit, wide body	0459 145 880
Handles incl mounting screws for Multi voltage unit (compl set = 2)	0459 307 881
Trolley	0458 530 880
Guide pin (if no trolley)	0458 731 880
Connection cable, 1.7 m	0460 210 880
Connection cable, 8.0 m	0460 210 881

Delivery includes:
5 m mains cable incl plug and 5 m return cable incl earth clamp.

Welding automation

Mechanisation equipment



Railtrac 1000

Railtrac 1000 is a series of programmable and portable equipment for mechanising welding and cutting. Different solutions often provide the answer to monotonous, gruelling work and produce higher productivity and more consistent quality at the same time. Railtrac is specially designed for MIG/MAG and TIG welding and thermal cutting.

Railtrac is made up of robust components and is available in the following four basic models. All the models have five different programs, including interval welding. The rail can be fixed in place using suction cups of the ejector type, screw attachments or permanent magnets.

- Railtrac F1000, Flexi, the least complex equipment for welding or cutting along a combi-rail, either flexible or stiffened.
- Railtrac FW1000, Flexi Weaver, the Flexi system plus a remote-control unit and a weaving device which makes it possible to weave the arc according to different patterns.
- Railtrac FR1000, Flexi Return, has the combi-rail. It also has movable start and stop indicators for automatic operation.
- Railtrac FWR1000, Flexi Weaver Return, also has the flexible combi-rail, a remote-control unit, a weaving device and start and stop indicators for automatic operation.

Using the remote control, it is possible to select:

- Start and stop
- Travel or welding direction/cutting direction
- Travel or welding speed/cutting speed
- Weaving width
- Zero-line displacement
- Rapid speed on/off
- Backfill function
- Potentiometer control of welding parameters

Railtrac 1000

Rail length, m	2.5
Rail bending radius, min, mm	1000
Welding speed, m/min	0.10-1.5
Transport speed, m/min	1.5
Weaving range, mm	1-30
Weaving speed, mm/s	6-60
Dwell time, s	0.0-9.9



Welding automation

Mechanisation equipment



Railtrac F1000

Railtrac F1000, Flexi, for welding and thermal cutting.

- Welds and cuts in all positions on magnetic and non-magnetic materials
- Quick assembly and easy operation
- Programmable with five programs
- Calibrated setting values in cm, mm and sec
- Programmable "backfill" for crater filling
- Self-instructive programming manual
- Stiff or flexible, robust rail made of standard aluminium profiles without racks
- Track which can be extended or cut to required length
- Angled attachment for quick adjustment of pistol angle (option)
- "Floating" head for mechanical height maintenance (option)



Railtrac FR1000

Railtrac FR1000, Flexi Return, for welding and cutting with automatic return.

- Welds and cuts in all positions on magnetic and non-magnetic materials
- Quick set-up and easy operation
- Programmable with five programs
- Calibrated setting values in mm, cm and sec
- Programmable "backfill" for crater filling
- Self-instructive programming manual
- Stiff or flexible rail made of standard aluminium profiles without racks
- Rail which can be extended bent or cut
- Angle bracket for quick adjustment of torch angle (option)
- "Floating" head for mechanical height maintenance (option)



Railtrac FWR1000

Railtrac FWR1000, Flexi Weaver Return, for oscillated welding with automatic return.

- Welds in all positions on magnetic and non-magnetic materials
- Quick set-up and easy operation
- Programmable with five programs
- Calibrated setting values in mm, cm and sec
- Programmable "backfill" for crater filling
- Self-instructive programming manual
- Flexible rail made of standard aluminium profiles without racks
- Rail which can be extended or cut to required length
- Angle bracket for quick adjustment of torch angle (option)
- Tilttable weaving unit for fillet welds (option)
- Turnable weaving unit for horizontal weaving in sloping joints (option)
- "Floating" head for mechanical height maintenance (option)
- Potentiometers in the remote control for parameter adjustments



Railtrac FW1000/FW1000 L

Railtrac FW1000, Flexi Weaver, for oscillated welding. The Railtrac FW1000 can be delivered in a "FW1000 L" version if the welding process need to be done with a lower welding speed than with FW1000.

- Welds and cuts in all positions on magnetic and non-magnetic materials
- Quick set-up and easy operation
- Programmable with five programs
- Calibrated setting values in cm, mm and sec
- Self-instructive programming manual
- Resilient remote control with profiled membrane buttons
- Stiff or flexible rail made of standard aluminium profiles without racks
- Rail which can be extended or cut to required length
- Angle bracket for quick adjustment of torch angle (option)
- Tilttable weaving unit for fillet welds (option)
- Turnable weaving unit for horizontal weaving in sloping joints (option)
- "Floating" head for mechanical height maintenance (option)
- Potentiometers in the remote control for parameter adjustments



Welding automation

Mechanisation equipment



Railtrac BV1000/BVR1000

Railtrac BV1000 and BVR1000 are two automatic units for mechanising the repair and hardfacing of rail profiles smoothly and efficiently. The equipment can be assembled, programmed and controlled quickly and easily by one person. Learning to use it is easy and handling is extremely fast.

The system comprises two rail fasteners, a stable aluminium profile, a carriage with a weaving unit, control electronics and remote control. The weaving unit and control electronics are fully synchronised to enable a number of weaving patterns to be pre-programmed.

The weaving movements start from a laterally adjustable zero line, either the outer side or the inner side of the rail. This zero line can also be moved laterally during welding. Different speeds can be used in each program to produce the most consistent weld metal thickness possible.

The remote control unit enables the welder to have full control of all the movements of the machine without lifting his/her welding visor.

Railtrac BV1000, with a weaving device and four different programs.

Railtrac BVR1000, with a weaving device, start and stop indicators, return function for automatic operation and six different programs.

Railtrac BV/BVR

Rail length, m	2
Welding speed, m/min	0.1-1.5
Weaving range, mm	1-80
Weaving speed, mm/s	7-50
Max power consumption, W	80
Control voltage, V, AC	36-46
Crater fill duration, s	0-9.9
Zero-line shift, mm	25 (Δ 12.5)
Programmable edge length, cm	6-99
Weight, kg	7



Tramtrac™ II

Tramtrac™ II is a light weight tractor for repairing worn city tram rails. It has a wire feed unit and controls for travel speed, wire feed speed, inching and start/stop of the welding process.

The best way to get most out of your Tramtrac™ II is to use it together with either OK Tubrodur 14.71 or OK Tubrodur 15.65. Both are self shielded wires needing no shielding gas and the best power source to use is the Origo™ Mig 410.

Tramtrac™ II

Welding speed, m/min	0.3-1.1
Control voltage, V, AC	36-46
Power, W	90
External dimensions, LxWxH	600x300x150
Weight, without consumables, kg	12

Ordering information

Tramtrac™ II	0814 721 880
Connection cable 10 m	0457 360 884
Accessories:	
Magnetic earth clamp	0000 500 415

Welding automation

Mechanisation equipment



Frametrac™

The Frametrac™ is a superb alternative when you wish to automate your frame welding. It is built for use together with ESAB's semi-automatic power sources and feed units.

The Frametrac™ is a compact, motor-powered tractor that travels on the door frame to be welded. The four driving wheels guarantee an even, stable movement on the frame.

A standard ESAB torch can be mounted in the torch attachment and can be adjusted to fit your frame and type of welding.

From the control box and from the remote control you can control travel direction and speed, weaving speed and width. To secure best possible arc stability, Frametrac™ is equipped with an automatic current control, ACC, that holds the arc length stable.

Frametrac™

Welding speed, m/min	1.0-9.9
Control voltage, V, AC	36-46
Power, W	80
External dimensions, LxWxH	280x430x508
Weight, without consumables, kg	30

Ordering information

Frametrac with ACC	0449 925 880
Connection cable (2 pcs needed)	0457 360 880

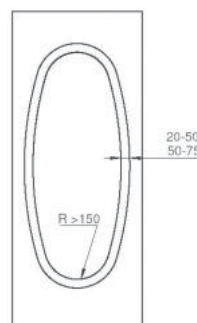

Frame 1
On this type of frame, the Frametrac can be used directly.

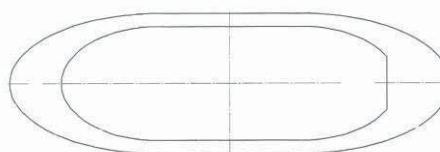

Frame 2
On this type of frame, a template is needed.

Welding automation

Mechanisation equipment/Tractor automats

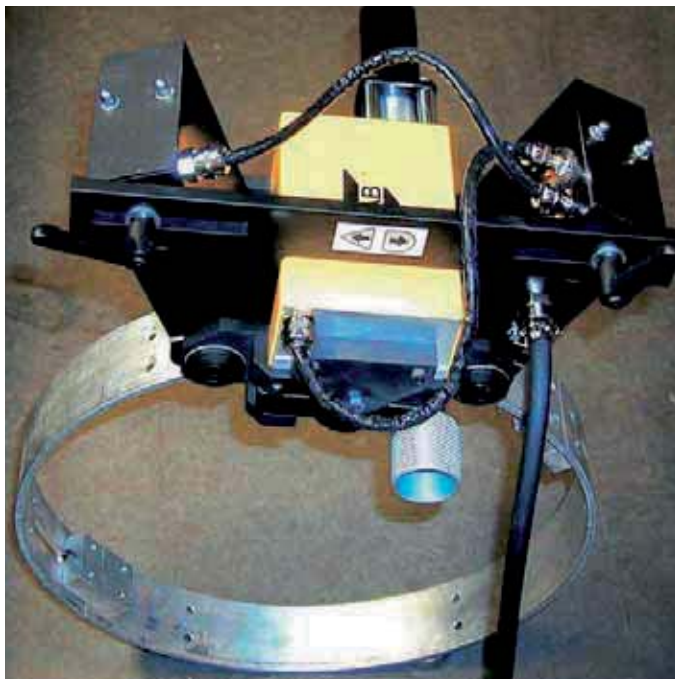

Railtrac Orbital W

The Railtrac Orbital W is a superb alternative if you wish to automate your tube welding. It is ideal for use with ESAB's semi-automatic power sources and feed units.

The Railtrac Orbital W is a small, compact, motor powered tractor to which a standard ESAB welding torch can be attached quickly. Two motors guarantee an even, stable movement on the rail.

Railtrac Orbital W

Welding speed, m/min	0.05-0.99
Weaving range, mm	1-30
Weaving speed, mm/s	6-60
Max power consumption, W	90
Control voltage, V, AC	36-46
Weight, kg	8

Ordering information

Railtrac Orbital W 0398 146 032

Accessories:

Floating head 0398 145 211

Ring sizes from 6" - 78", please contact your nearest ESAB representative.



Miggytrac 1001

The Miggytrac 1001 is a small and compact, motor-powered tractor to which a standard ESAB welding torch can be quickly attached.

The four driving wheels, together with the magnet which is fitted on the tractor, guarantee even, stable movement. The magnet holds the tractor in the correct position on the workpiece, even if it is bent or angled. The tractor functions as a straightforward remote control for the feed unit; you decide on the travel direction and then start and stop welding from the panel. The panel features additional functions such as travel speed settings, wire feed, voltage and welding on/off. The tractor follows the joint using guide wheels.

Miggytrac 1001

Welding speed, m/min	0.15-1.2
Control voltage, V, AC	36-46
Power, W	20
Weight, kg	7
External dimensions, LxWxH, mm	266x257x267

Ordering information

Miggytrac 1001 0457 357 881

Connection cable to wire feed unit 0457 360 880

Welding screen 0457 463 880

Universal connectors:
Transformers 230/36 V 0457 467 880

Universal connection cable for other brands 0457 360 881

Welding automation

Tractor automats



Miggytrac 2000

The Miggytrac 2000 is a small, compact, motor-operated trolley that is designed for the mechanisation of GMAW, gas metal arc welding, in particular. Just fix the torch in the holder and Miggytrac 2000 will take over the welding procedure. The permanent built-in magnet, which can be switched on/off, holds the tractor in the correct position on the workpiece. The lightweight trolley has four-wheel drive to ensure smooth and steady welding travel.

The Miggytrac 2000 has a digital display to permit simple programming. It is very easy to move the trolley from one welding task to the next.

Miggytrac 2000

Travel speed, m/min	2.5
Welding speed, m/min	0.15-1.5
Control voltage, V, AC	36-46
Max power consumption, W	40
Intermittent welding range, cm	1-99
Crater fill duration, s	0-9.9
Weight, kg	9.5
External dimensions, LxWxH, mm	330x260x360

Ordering information

Miggytrac 2000	0457 358 880
Connection cable to wire feed unit	0457 360 880
Welding screen	0457 463 880
Universal connectors	
Transformers 230/36 V	0457 467 880
Universal connection cable for other brands	0457 360 881



Miggytrac 3000

The Miggytrac 3000 is designed to be used together with ESAB's semi-automatic power sources.

The Miggytrac 3000 is a small, compact, motor-powered tractor with integrated wire feed and water-cooled welding torch, designed for horizontal MIG/MAG welding of plates and beams. Miggytrac 3000 is provided with four-wheel drive. The carriage follows the weld joint by means of one front and one rear guide wheel. The wheels are adjusted so as to make the carriage travel diagonally towards the flange or stiffener to be welded.

Miggytrac 3000

Travel speed, m/min	2.5
Welding speed, m/min	0.15-1.5
Control voltage, V, AC	36-46
Max power consumption, W	80
Intermittent welding range, cm	1-99
Crater fill duration, s	0-9.9
Weight, kg	17
External dimensions, LxWxH, mm	370x400-530x520

Ordering information

Miggytrac 3000, with straight water-cooled swan neck	0457 359 880
Contact tip 1.0 CO ₂	0468 502 005
Contact tip 1.2 CO ₂	0468 502 007
Contact tip 1.4 CO ₂	0468 502 008

Welding automation

Tractor automats



A2 Multitrac with A2/A6 process controller PEK

The A2 Multitrac with the A2/A6 process controller PEK is available for both the SAW and the GMAW method.

If the SAW-version is chosen, the A2 Multitrac is capable of working equally well with either single or twin wire.

The feed unit secures an even and stable wire-feed speed.

Accurate travel speed is ensured by means of four-wheel drive.

Exact presetting and control of the welding parameters is done on the instrument panel, which is equipped with a digital display.

The Multitrac is fully mobile and can easily be moved from one welding station to another. It can also be quickly set-up for different workpieces.

	Single SAW	Twin SAW	Single GMAW	Single GMAW with MTW 600
Wire Ø, unall. solid	1.6-4.0	2x1.2-2.5	0.8-1.6	1.0-1.6
Wire Ø, SS	1.6-4.0	2x1.2-2.5	0.8-1.6	1.0-1.6
Wire Ø, Al	-	-	1.2-1.6	1.0-2.0
Wire Ø, CW	1.6-4.0	-	1.2-2.4	1.0-2.4
Wire feed, m/min	0.2-9	0.2-9	0.2-16	2.0-25
Travel speed, m/min	0.1-1.7	0.1-1.7	0.1-1.7	0.1-1.7
External dimensions, LxWxH, mm	870x400 x830	870x400 x830	870x400 x830	870x400 x830
Weight, kg	47	47	43	43

Ordering information

A2 Multitrac A2TF with A2/A6 process controller PEK (SAW single)	0461 233 880
A2 Multitrac A2TF with A2/A6 process controller PEK (SAW/ Twin)	0461 233 881
A2 Multitrac A2TG with A2/A6 process controller PEK (GMAW)	0461 234 880
A2 Multitrac A2TG with A2/A6 process controller PEK (GMAW with MTW 600)	0461 234 881
Wear parts, see page 90-91	



A2 Multitrac with A2 process controller PEI

The A2 Multitrac with the process controller PEI is available for both the SAW and the GMAW method.

If the SAW-version is chosen, the A2 Multitrac is capable of working equally well with either single or twin wire.

The feed unit secures an even and stable wire-feed speed.

Accurate travel speed is ensured by means of four-wheel drive.

The control equipment is very easy to use with a minimum of training. The welding parameters are adjusted by turning knobs and the actual parameters are shown on the digital displays.

The Multitrac is fully mobile and can easily be moved from one welding station to another. It can also be quickly set-up for different workpieces.

	Single SAW	Twin SAW	GMAW
Max load at 100% duty cycle, A	800	800	600
Wire Ø, unall. solid	1.6-4.0	2x1.2-2.5	0.8-1.6
Wire Ø, SS	1.6-4.0	2x1.2-2.5	0.8-1.6
Wire Ø, Al	-	-	1.2-1.5
Wire Ø, CW	1.6-4.0	-	1.2-2.4
Wire feed, m/min	0.2-9	0.2-9	0.2-16
Travel speed, m/min	0.1-1.7	0.1-1.7	0.1-1.7
External dimensions, LxWxH, mm	870x400 x860	870x400 x860	870x400 x860
Weight, kg	47	47	43

Ordering information

A2 Multitrac with A2 process controller PEI SAW	0449 360 880
A2 Multitrac with A2 process controller PEI SAW Twin	0449 360 881
A2 Multitrac with A2 process controller PEI GMAW	0449 361 880
Wear parts, see page 90-91	

Welding automation

Tractor automats



A2 Tripletrac

The A2 Tripletrac is superb for internal circumferential welding of large cylindrical objects due to its clever design with a steering wheel. The tractor can be equipped with ESAB's A2-A6 Process Controller PEK or A2 Welding Controller PEI.

The A2 Tripletrac's three-wheeled tractor carriage steers with the front wheel. This, combined with the fact that the steering wheel also controls the horizontal slide, ensures easy control of the wire position. This makes the A2 Tripletrac ideal for internal circumferential welding of large cylindrical objects that are rotating on a roller bed, for example pressure vessels and wind towers.

The compact, efficient design makes it easy to move the A2 Tripletrac from one place to another, such as between different welding workpieces. The carriage is equipped with a handle to disengage the gear, so the A2 Tripletrac can easily be pushed to another place.

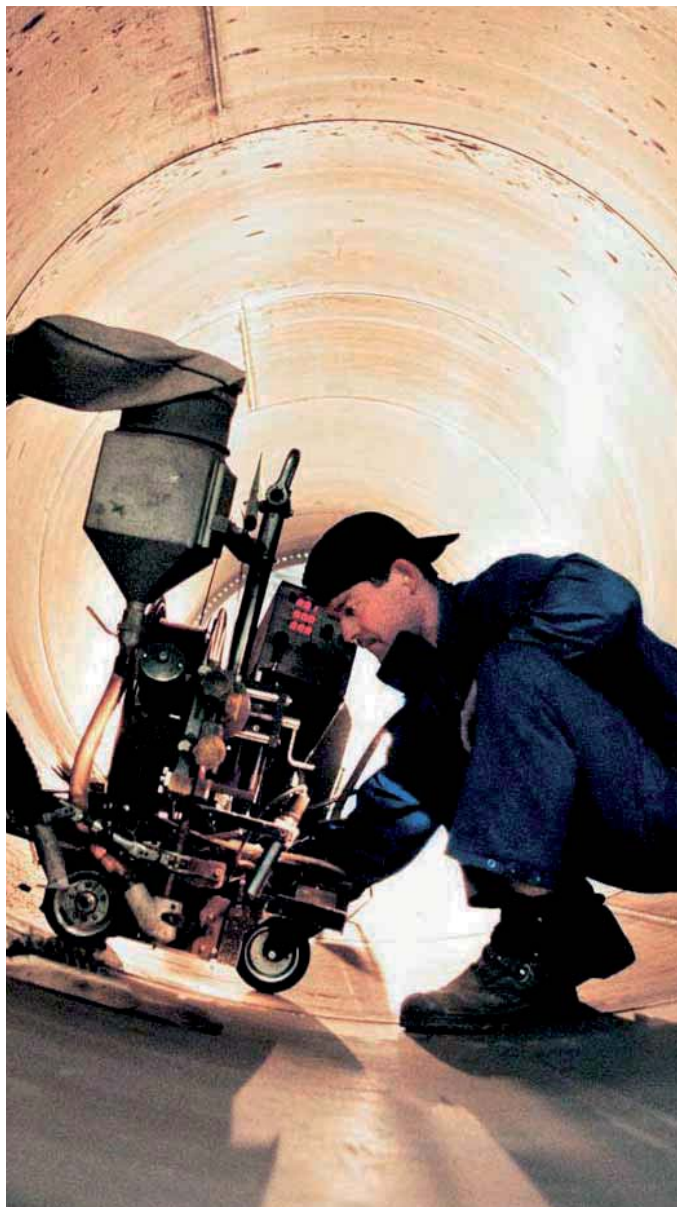

Single SAW

Max load at 100% duty cycle, A	800
Wire Ø, unall. solid	1.6-4.0
Wire Ø, SS	1.6-4.0
Wire Ø, CW	1.6-4.0
Wire feed, m/min	0.2-9
Travel speed, m/min	0.1-1.7
External dimensions, LxWxH, mm	594x686x956
Weight, kg	47 (excl wire, flux)

Ordering information

A2 Tripletrac with process controller PEK	0461 236 880
A2 Tripletrac with process controller PEI	0449 430 881

Welding automation

Tractor automats



A6 Mastertrac

The A6 Mastertrac is a heavily-dimensioned self-propelled, four-wheel drive, automatic welding machine. The advanced electronic control equipment provides high precision and the digital display enables all the welding parameters to be preset accurately – either beforehand or during welding. The A6 Mastertrac is easy to use and once it is running, it requires only the supervision of the operator. The automat can be supplied for SAW in single, twin or tandem version. Also available for GMAW.

The picture shows A6 Mastertrac Tandem.

	Single SAW	Single GMAW	Twin SAW	Tandem SAW
Max load at 100% duty cycle, A	1500	600	1500	2x1500
Wire diameter, mm	3.0-6.0	1.0-3.2	2x2.0-3.0	2x3.0-6.0
Wire feed, m/min	0.2-4.0	0.8-16.6	0.2-4.0	0.2-4.0
Travel speed, m/min	0.1-2.0	0.1-2.0	0.1-2.0	0.1-2.0
External dimensions, LxWxH, mm	1410x750x850	1410x750x850	1410x750x850	1410x990x850
Weight, kg	110	100	110	158

Ordering information

A6 Mastertrac A6TF (SAW)	0461 235 880
A6 Mastertrac A6TF (SAW, Twin)	0461 235 881
A6 Mastertrac A6TF (SAW, high-speed)	0461 235 890
A6 Mastertrac A6TF (SAW, Twin, high-speed)	0461 235 891
A6 Mastertrac tandem A6TF (SAW, DC/AC 1500)	0461 232 882
Wear parts, see page 90-91	



A6-DK

The A6-DK welding machine has two welding heads. It is built up by components from the well-known A6 system. A6-DK is designed for simultaneously welding horizontal-vertical fillets on both sides of a web or through panels.

A6-DK straddles work pieces up to 800 mm high and with a symmetrical profile of 400 mm. A6-DK travels directly on the work piece and is guided along the joint with the aid of a guide unit attached to the contact unit. The travel speed is steplessly adjustable from 0.15 to 2.0 m/min.

A6-DK SAW	
Max load at 100% duty cycle, A	1500
Wire diameter, mm	3.0-6.0
Wire feed, m/min	0.2-4.0
Travel speed, m/min	0.15-2.0
External dimensions, LxWxH, mm	870x400x830
Vertical space limitation, mm	800
Longitudinal symmetrical extension, mm	400
Weight, kg	150

Ordering information

A6-DK SAW single wire excl. wire reel, feed rollers and contact jaws*	0461 237 901
Wire reel plastic 30 kg	0153 872 880
Wire reel steel 30 kg	0416 492 880
*When contact equipment is excluded feed rollers and contact jaws have to be ordered separately.	

Welding automation

Storage and tank welder



AGW1 and AGW2 Single-side & Double-side tank welder

AGW1 and AGW2 Tank Welder is a series of self-propelled 3 o'clock welding equipment primarily developed for on-site erection of large storage tanks, silos, blast furnaces and similar cylindrical objects. It is available as a single-side version and a double-side version. Usually it is designed to travel on the top edge of the tank shell.

As there are different ways of building tanks, one machine in the series is designed to travel on a rail which is temporarily fixed to the shell or on a stand-alone ring outside the shell.

Operator safety CE approved

The operator of each machine (if a double-side version) rides in a cabin, where he supervises and controls the welding process with the control panel within easy reach.

For weather protection the cage can be covered by curtains. The cabin of a double-side machine is equipped with step ladders and a joining bridge at the top to facilitate for the operators to climb onboard. The bridge also has guard rails for the safety of the operators.

For more information, please contact your nearest ESAB representative.

Welding automation

Welding heads



A2 S Mini Master

The A2 S Mini Master represents an automatic welding system designed with the emphasis on low weight, compactness and flexible use. The system is built around basic units. The degree of automation and process orientation of the basic unit you choose can be expanded or modified as required, depending on the application. Appropriate welding heads can be combined with suitable manipulators, which results in a total solution to a specific welding problem.

	Single SAW	Twin SAW	Single GMAW
Max load at 100% duty cycle, A	800	800	600
Wire feed, m/min	0.2-9	0.2-9	0.2-16

Ordering information

For ordering information please contact your nearest ESAB representative
Wear parts, see page 90-91



A2 S GMAW Mini Master

The A2 S GMAW Mini Master is a compact MIG/MAG version of the A2 S SAW Mini Master welding head. The GMAW welding head is equipped with an MTW 600 welding torch, which is specially designed for use where an automatic MIG/MAG welding torch is required for heavy-duty use.

The very effective "whirlcool liquid cooling system" is integrated in both the contact tube and the outer jacket of the torch for maximum cooling effect. All connections are positioned in the upper end of the torch to facilitate the mounting of the necessary supply and to protect the connection from welding arc radiation.

	Single GMAW
Max load at 100% duty cycle, A - Mix/Ar	600
Max load at 100% duty cycle, A - CO ₂	650
Wire feed, m/min	2.0-25

Ordering information

For more information, please contact your nearest ESAB representative.
Wear parts, see page 90-91

Welding automation

Welding heads

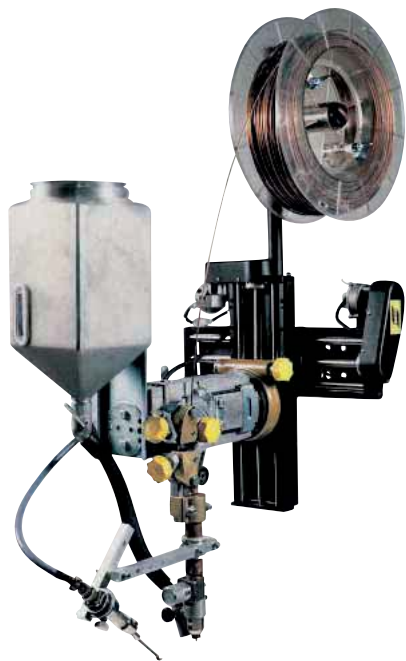

A6 S Arc Master

The A6S Arc Master is the complete system for heavy production welding offering flexibility, operational reliability and durability. It constitutes the base of ESAB's automatic welding program with an extensive modular and component system. It is available in a number of standard models and can be adapted to suit the customer's specific demands.

From an existing model, the A6 S can be rebuilt and extended to the required automation level, by means of positioning, joint tracking, flux handling and so on, as the requirements change.

	Single SAW, 156:1	Twin SAW, 156:1	Single SAW, 74:1	Twin SAW, 74:1	Single GMAW, 74:1
Max load at 100% duty cycle, A	1500	1500	1500	1500	600
Wire diameter, mm	3.0-6.0	2x2.0-3.0	1.6-4.0	2x1.6-2.0	0.8-3.2
Wire feed, m/min	0.2-4.0	0.2-4.0	0.4-8.0	0.4-8.0	0.8-16.6

Ordering information

For ordering information, please contact your nearest ESAB representative
Wear parts, see page 90-91

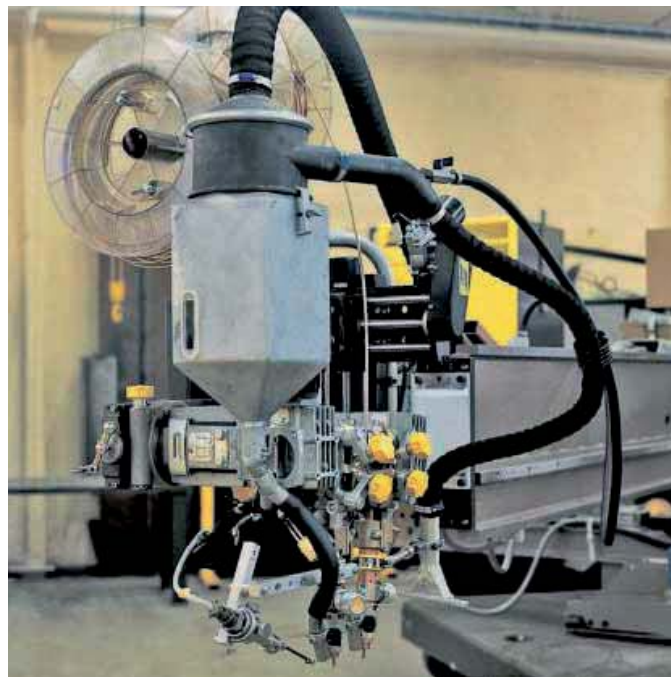

A6 S Tandem Master

The A6 S Tandem Master is a highly versatile welding automat equipped with two A6 heads – for either DC/DC or DC/AC welding.

Direct current provides good penetration, whereas alternating current secures a high deposition rate. The A6 S Tandem Master is available in a number of models to match the customer's safety, quality and productivity requirements.

A6 S Tandem Master	
Max load at 100% duty cycle, A	2x1500
Wire diameter, mm	2x3.0-6.0
Wire feed, m/min	0.2-4.0

Ordering information

For ordering information, please contact your nearest ESAB representative.

Welding automation

Welding heads/Power sources



A6 S Compact

The A6 S Compact 300/500/700 are three reliable members of the A6 family for the efficient, high-productivity SAW method. These welding heads make it possible to build highly-efficient stations for the internal longitudinal welding of butt joints inside tubes in different versions for tubes down to dia 300 mm. TV-monitoring equipment can be integrated into the system, thereby enabling the operator to supervise and adjust the head position from the outside via the TV -screen.

A6 S Compact	
Max load at 100% duty cycle, A	800
Wire diameter, mm	2.5, 3.0, 4.0
Wire feed, m/min	0.4-8.0

Ordering information

For ordering information please contact your nearest ESAB representative



TAF 801 and 1251

The AC power sources TAF 801 and TAF 1251 are using a unique square wave technology suitable for a wide range of AC welding applications.

- Capacity for continuous welding
- Pre-setting of arc voltage
- Reliable square wave striking
- Arc voltage or current feed back
- Optimized open circuit voltage
- Compensation of mains voltage fluctuation
- Voltage drop compensation for long welding cables
- High power factor ensuring low power consumption
- Designed and built for convenient servicing
- Safety control voltage 42V
- Prepared for Scott connection of two power sources

	TAF 801	TAF 1251
Max output at 60% duty cycle, A	1000/44	1500/44
Max output at 100% duty cycle, A	800/44	1250/44
Setting range, A/V	300/28-800/44	400/28-1250/44
Open circuit voltage, V	71	72
Efficiency at max current	0.86	0.86
Power factor at max current	0.75	0.76
Voltage, 1 ph 50 Hz, V	400/415/500	400/415/500
Voltage, 1 ph 60 Hz, V	400/440/550	400/440/550
Enclosure class, protection	IP23	IP23
External dimensions, LxWxH, mm	774x598x1428	774x598x1428
Weight, kg	495	608

Ordering information

TAF 801 0460 516 880
 TAF 1251 0460 517 880
 For more information, please contact your nearest ESAB representative.

Welding automation

Power sources



LAF 631, 1001, 1251 and 1601

The LAF series are three phase, fan-cooled DC welding power sources designed for high productivity mechanized submerged or high productivity MIG/MAG arc welding.

They are used in combination with ESAB's A2-A6 equipment range and the A2-A6 Process Controllers (PEK or PEI).

	LAF 631	LAF 1001	LAF 1251	LAF 1601
Max output at 60% duty cycle, A	800/44	1000/44	-	-
Max output at 100% duty cycle, A	630/44	800/44	1250/44	1600/44
Setting range, A/V, MIG/MAG	50/17-630/44	50/17-1000/45	60/17-1250/44	-
Setting range, A/V, SAW	30/21-800/44	40/22-1000/45	40/22-1250/44	40/22-1600/46
Open circuit voltage, V	54	52	51	54
No load power, W	150	145	220	220
Efficiency at max current	0.84	0.84	0.87	0.86
Power factor at max current	0.90	0.95	0.92	0.87
Voltage, 3 ph 50 Hz, V	400/415	400/415/500	400/415/500	400/415/500
Voltage, 3 ph 60 Hz, V	440	400/440/550	400/440/550	400/440/550
Enclosure class, protection	IP23	IP23	IP23	IP23
External dimensions, LxWxH, mm	670x490x930	646x552x1090	774x598x1428	774x598x1428
Weight, kg	260	330	490	585

Ordering information

LAF 631	0460 512 880
LAF 1001	0460 513 880
LAF 1001 M	0460 513 881
LAF 1251	0460 514 880
LAF 1251M	0460 514 881
LAF 1601	0460 515 880
LAF 1601 M	0460 515 881

For more information, please contact your nearest ESAB representative.

Welding automation

Wear parts

*Tandem head - see single head SAW
tw = twin wire, s = single wire, G = GMAW

Contact nozzles wire size

Ordering information

M6 0.8 mm	0153 501 002
M6 1.0 mm	0153 501 004
M6 1.2 mm	0153 501 005
M6 1.6 mm	0153 501 007
M6 2.0 mm	0153 501 009
M6 2.4 mm	0153 501 010
M10 0.8 mm	0258 000 914
M10 1.0 mm	0258 000 913
M10 1.2 mm	0258 000 908
M10 1.6 mm	0258 000 909
M10 2.0 mm	0258 000 910
M10 2.4 mm	0258 000 911
M10 3.2 mm	0258 000 915
M12 1.6 mm	0154 623 008
M12 2.0 mm	0154 623 007
M12 2.4-2.5 mm	0154 623 006
M12 3.0 mm	0154 623 005
M12 4.0 mm	0154 623 003

A2 Multitrac		A6* Mastertrac		A2 Mini Master		A6* Arc Master		A6 Compact	
SAW	G	SAW	G	SAW	G	SAW	G	SAW	
s	tw	s	tw	s	tw	s	tw	single	
		•			•			•	
		•			•			•	
	•	•		•	•			•	•
	•	•		•	•			•	•
	•		•		•			•	
	•				•				
		•			•			•	
		•			•			•	
		•			•			•	
		•			•			•	
•			•		•			•	
•			•		•			•	
•			•		•			•	
•			•		•			•	
•			•		•			•	

Adapter M6/M10

Ordering information

Adapter M6/M10	0147 333 001
----------------	--------------

		•			•			•			•	
--	--	---	--	--	---	--	--	---	--	--	---	--

Contact jaws D35

Ordering information

2.0 mm L=65 mm	0332 581 880
2.4-2.5 mm L=65 mm	0332 581 881
3.0 mm L=58 mm	0265 900 880
4.0 mm L=58 mm	0265 900 882
5.0 mm L=58 mm	0265 900 883
6.0 mm L=58 mm	0265 900 884
1.6-3.2 mm L=75 mm	0265 901 480

												•
												•
			•						•			•
			•						•			•
			•						•			
			•						•			
			•						•			

Contact jaws heavy twin

Ordering information

2 x 1.6 mm	0265 902 882
2 x 2.0 mm	0265 902 881
2 x 2.4-2.5	0265 902 884
2 x 2.5-3.0 mm	0265 902 880

	•			•			•			•		
	•			•			•			•		
	•			•			•			•		
	•			•			•			•		

Feed roller single wire size

Ordering information

0.8 mm	0145 538 881
1.0 mm	0145 538 882
1.2 mm	0145 538 883
1.6 mm	0218 510 281
2.0 mm	0218 510 282
2.4-2.5 mm	0218 510 283
3.0-3.2 mm	0218 510 298
4.0 mm	0218 510 286
5.0 mm	0218 510 287
6.0 mm	0218 510 288
3.0-5.0 mm Knurled V-groove	0218 510 299

		•					•					
		•		•			•					
			•	•			•					
•		•	•	•	•		•	•				
•		•	•	•	•		•	•				•
•		•	•	•	•		•	•				•
•		•	•	•	•		•	•				•
•		•	•	•	•		•	•				•
			•		•		•					
			•		•		•					

Pressure roller, single wire

Ordering information

Pressure roller, single wire	0153 148 880
------------------------------	--------------

			•				•					
--	--	--	---	--	--	--	---	--	--	--	--	--

Welding automation

Wear parts

*Tandem head - see single head SAW
tw = twin wire, s = single wire, G = GMAW

Feed roller grooved

Ordering information

Tubular wire 1.2-1.6 mm 0146 024 880
Tubular wire 2.0-4.0 mm 0146 024 881

A2 Multitrac		A6* Mastertrac		A2 Mini Master		A6* Arc Master		A6 Compact
SAW	G	SAW	G	SAW	G	SAW	G	SAW
s	tw	s	tw	s	tw	s	tw	single
		•	•		•	•		•
		•	•		•	•		•

Pressure roller wire size

Ordering information

0.8-1.6 mm 0146 025 880
2.0-4.0 mm 0146 025 881
Shaft stud for above pressure roller 0212 901 101

		•	•		•	•		•
		•	•		•	•		•
		•	•		•	•		•

Feed roller twin wire size

Ordering information

2 x 1.2 mm 0218 522 486
2 x 1.6 mm 0218 522 488
2 x 2.0 mm 0218 522 484
2 x 2.4-2.5 mm 0218 522 480
2 x 3.0 mm 0218 522 481
2 x 2.0-3.2 mm Knurled U-groove 0148 772 880

	•			•				•
	•			•				•
	•			•				•
	•			•				•
				•				•
				•				•

Pressure roller, twin wire

Ordering information

Pressure roller, twin wire 0218 524 580

	•			•				•
--	---	--	--	---	--	--	--	---

MTW 600 MIG Torch

Contact nozzle M8

Ordering information

1.0 mm Fe, Ss, Cw / Al 0457 625 005
1.2 mm Fe, Ss, Cw 0457 625 006
1.2 mm Al 0457 625 007
1.4 mm Fe, Ss, Cw 0457 625 008
1.6 mm Fe, Ss, Cw / Al 0457 625 009
2.0 mm Al 0457 625 011
2.4 mm Fe, Ss, Cw / Al 0457 625 012

		•			•				•
		•			•				•
		•			•				•
		•			•				•
		•			•				•
		•			•				•
		•			•				•

A2 4WD Wire feeder

Feed roller single solid wire

Ordering information

0.6-0.8 mm Fe, Ss 0369 557 001
0.8-0.9 mm Al 0369 557 011
0.8-1.0 mm Fe, Ss 0369 557 002
1.0-1.2 mm Fe, Ss 0369 557 003
1.0-1.2 mm Al 0369 557 006
1.2-1.6 mm Fe, Ss 0369 557 007
1.4-1.6 mm Fe, Ss 0369 557 013
1.6 mm Al 0369 557 008
2.0 mm Al 0369 557 009
2 x 1.2 mm Fe, Ss 0369 557 010
Pressure roller (flat) 0369 728 001

		•			•				•
		•			•				•
		•			•				•
		•			•				•
		•			•				•
		•			•				•
		•			•				•
		•			•				•
		•			•				•
		•			•				•

Knurled feed roller single wire

Ordering information

1.0-1.2/1.4-1.6 mm Cw 0369 557 004
1.4-1.6/2.0-2.4 mm Cw 0369 557 005
Pressure roller (knurled) 0466 262 001

		•			•				•
		•			•				•
		•			•				•

Welding automation

Carriers and gantries



A2/A6 Beam-travelling carriage

For many applications, a beam-mounted carriage, fitted with an A2 or A6 welding head, is the ideal solution for submerged arc and gas metal arc welding.

The beam-bound carriage has a robust, cast-metal chassis with the opportunity to mount a standard A2S or A6S welding head.

A2/A6 Beam-travelling carriage

Travel speed, m/min	0.06-2.0
Weight, kg	60

Ordering information

For ordering information, please contact your nearest ESAB representative.



MechTrac 1730, 2100, 2500 and 3000

MechTrac might very well be the most flexible and fastest way to increase your productivity. The MechTrac is built as a gantry and can be equipped with an A2 welding equipment for SAW or MIG/MAG to create a complete welding station. If the workpiece rotates, other welding methods such as TIG and Plasma can be used, depending on the application and handling equipment. The MechTrac unit is suitable for different types of workpieces that can be covered by a gantry. The gantry offers the possibility to weld profiles such as I-, T-, or L-beams, columns or tapered beams. The MechTrac is available in four versions, depending on the size of the workpiece. The difference is the width of the gantry – 1730 mm, 2100 mm, 2500 mm or 3000 mm between the legs.

The length of the legs is the same for all types, 1500 mm from the top of the rail to the inside of the overhead beam.

The gantry can support a maximum weight of 220 kg, corresponding to a maximum of two A2 welding heads (single or twin wire) complete with automatic joint tracking GMH and an OPC flux recovery unit.

The picture shows MechTrac equipped with A2 welding heads, Process Controller PEK and Power sources LAF 631.

MechTrac 1730, 2100, 2500 and 3000

Travel speed, m/min	0.2-1.9
Rail length, m	3
Max load, kg	220

Ordering information

MechTrac 1730, dual drive	0809 670 881
MechTrac 2100, dual drive	0809 670 882
Mech Trac 2500, dual drive	0809 670 883
MechTrac 3000, dual drive	0809 670 884
Travelling rail, 3 m	0806 707 880
Rail, 3 m to extend the travelling rail	0806 707 881

Welding automation

Carriers and gantries



Walltrac

This column and boom welding station is designed for the production of various beam structures, such as I/H and box beams of tapered and non-symmetrical designs, stiffener sections and the joining of plates and sections. The flexible solution also permits quite a number of other applications to improve productivity and weld quality.

The wall-supported manipulator travelling on a single rail is designed for rack-and-pinion drive from the floor-mounted rail. An idler wheel support mounted on the column allows the manipulator to travel on a rail support.

To ensure a uniform, stable welding speed, the bogie carriage is equipped with two parallel-connected DC motors. The fixed boom, which has rails and a rack, is equipped with two motorised side-running welding carriages, each carrying a twin-wire sub-arc-welding head. Each welding head is fitted to a servo-controlled slide which is cross mounted on the carriage via a manually-adjusted vertical boom. Transverse welding with the speed generated from the side-running carriage is possible, using the outer welding head.

The well-proven A6 welding heads incorporating the user-friendly, microprocessor based PEK are a combination which safely secures the welding process. Automatic joint tracking GMH controls the vertical and horizontal axes, i.e. the slides and the carriages, to safeguard the superior weld quality.

Advantages: Minimal floor working area thanks to the single rail/wall support. Longitudinal and transverse welding procedures can be used. A large number of positioning axes permit flexible welding production.

Ordering information

For ordering information please contact your nearest ESAB representative.



Gantrac

This gantry has rigid legs supported by tacho-controlled bogie carriages with cable chains to ensure a uniform, stable welding speed. The two legs support the gantry beam, which is equipped with guides and a rack for the two motorised welding carriages. The operator can easily control the welding procedure from the platform mounted on one of the bogie carriages. All in all, this is a very sturdy and reliable manipulator solution.

The well-proven A6 welding heads are mounted on rack-and-pinion slides with comprehensive working strokes to obtain good access to the workpieces. Incorporating the user-friendly, microprocessor-based PEK, the welding process is safely secured. Automatic joint tracking GMH controls the vertical and horizontal axes, i.e. the slides and the carriages, to safeguard the superior weld quality.

Submerged arc welding is the superior method for the applications intended for this station.

The flux-handling equipment can be operated conveniently, without time-wasting interruptions. At the same time as flux consumption is reduced, the workplace is kept clean and free from flux spillage.

Advantages: Highly stabilised manipulation of welding torches with optimised welding results.

A large number of positioning axes permit flexible beam production.

Ordering information

For ordering information please contact your nearest ESAB representative.

Welding automation

Components and modules



OCE-2 H cooling unit

The OCE-2 H water-cooling unit is an efficient, compactly-dimensioned cooling unit designed for use together with water-cooled equipment for arc welding by hand or in automatic plants. The water tank and pump is made of corrosion-resistant material.

OCE-2 H	
Mains supply, V/Hz	230/50-60
Cooling water, l/min	6
Max water pressure, bar	2.8
External dimensions, LxWxH, mm	320x270x360
Weight, kg	15

Ordering information

Cooling unit OCE-2 H	0414 191 881
Flowguard	0414 231 880



A6 synergic cold wire

The ESAB A6 – SCW SAW process

The ESAB A6-SCW kit offers a unique opportunity to increase the productivity by boosting the deposition rate. The cold wire is fed in synergy with the arc wire into a weld pool where it melts. This means that the arc and cold wire ratio always remains constant after a suitable wire diameter is selected. The chemistry of the weld and the deposition rate is controlled and pre-selected. It is easy for the operator to use as no additional control unit or separate feed device is needed.

The SCW process can be used in an endless variety of combinations with solid and/or cored wires, single, twin, tandem, and multiple wire applications and so on. It can also be used in surfacing applications with cored/solid wires such as concast rollers or built-up, large-diameter engine pistons. The cold wire has no arc and therefore carries no restrictions when it comes to incorporating “hard to weld” alloys in cored wires.

The cold wire kit is suitable for all ESAB's new and existing A6 systems and can be installed in a few minutes.

Ordering information

For ordering information please contact your nearest ESAB representative

Slides

For the accurate and comfortable positioning of the welding head in the joint, the robust A2 and A6 slides are available in a series of standard lengths for any mounting position.

The A2 linear slides have a compact box profile and adjustable guides, which form a light and plain slide. The A6 linear slide is a flexible component and, with its high loading capacity, it can be freely mounted for positioning the A6 welding head. The A6 linear slide can also be supplied with an extended runner which increases loading capacity by 25%.

The A6 servo slide is primarily intended for use in connection with positioning and joint tracking. It can be operated jointly with other A6 components, such as rotary slides for the rotation of the welding head in the joint. These servo slides are normal supplementary units for our standard joint tracking systems, like the A6.

The ORB 40 is a rotary slide for the A2 welding head. It has a lockable rotary slide and compact design with a divided clamp. The A6 rotary slide with worm gear is used when the electrode angle requires frequent adjustment in relation to the joint. These adjustments can be made continuously from 0-360° using the hand-wheel. The A6 rotary ball bearing slide is another type designed for heavier loads. The rotary ball bearing disc can be rotated 360° and locked by a lever.

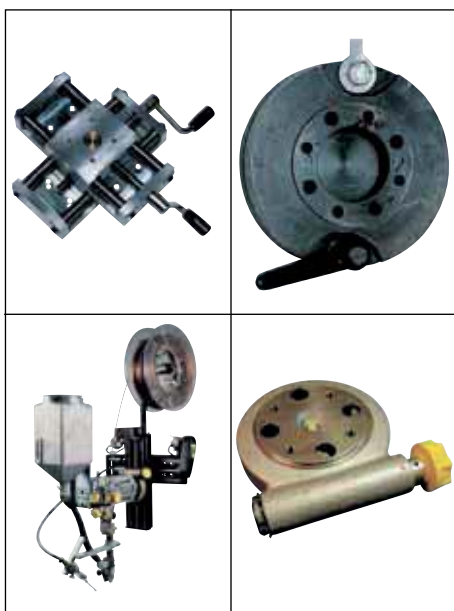

Welding automation

Components and modules



Wire feed units

The ESAB A2/A6 system comprises different wire feed units; A2 SAW, A2 GMAW, A6 SAW and A6 GMAW.

The A2 wire feed unit is designed for small wire Submerged Arc welding (SAW) or Gas Metal Arc welding (GMAW) while operating in confined spaces.

The A2 SAW wire feed unit can be used for single or twin-wire welding. The A6 SAW wire feed unit is designed for heavy-duty welding. The wire feed unit is the standard base in most SAW automatics in the heavy production industry. You can use single or twin wire, strip cladding or arc-air gouging. The A6 GMAW wire feed unit is specially designed for the mechanisation of MIG/MAG welding in steel and aluminium. The GMAW version is robust equipment for heavy-production welding. It has a water-cooled torch mounted directly on the feed unit.

A2-A6 Process Controller PEK

A2-A6 Process Controller PEK can be used with CAN controlled ESAB's power sources and motors. It is prepared for Submerged Arc Welding, Gas Metal Arc Welding and Arc gouging.

- Clear text menus for user friendliness
- CAN Bus controlled
- Selectable welding process
- Pre-setting of all welding parameters
- Memory for 255 parameter sets
- Constant current (CA) or constant wire speed (CW)
- Heat input visible on display
- Encoder controlled motors for top performance motion control
- USB slot for data backup and transfer
- Used welding parameters can be stored directly on a USB memory stick
- Data transfer to and from PC/LAN
- Documentation of used welding parameters on PC or through LAN with WeldPoint™



A2 process controller PEI

The A2 process controller PEI is a control system for ESAB A2 tractors and A2 welding heads. The controller is connected to the power source by a control cable and can be connected to the ESAB LAF 631 and 1001.

The A2 process controller PEI is suitable for both submerged arc welding and gas metal arc welding. The control system is very easy to use with a minimum of training.

A2 process controller PEI

Enclosure class, protection	IP 23
External dimensions, LxWxH, mm	197x227x220
Mains supply, V/Hz	42 (AC)/50-60
Weight, kg	6.2
Max power consumption, VA	700



Positioning and joint tracking system

The high-precision, heavy-duty A6 servo slide forms an important part of ESAB's automatic welding program. The slide is primarily intended for use in connection with positioning and joint tracking. Depending on the desired function and the work to be performed, the slide can be combined with two different control systems: PAV or GMH. The PAV is a manual, servo-assisted, joystick-controlled positioning and joint-tracking system for one or two slides. The GMH automatic joint-tracking system covers a wide range of applications and provides convenient handling. The basic function of the GMH is to correct irregularities in weld joints and to track simple workpiece geometries. You can also use sensor fingers with the GMH system to eliminate parallax faults.



Welding automation

Flux equipment

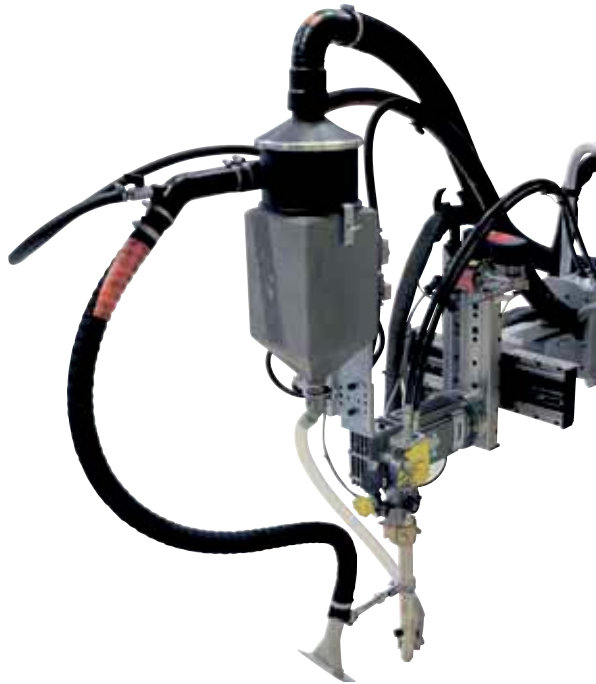

OPC Basic & Super flux equipment

ESAB has a number of different flux equipment/systems to combine with our automatic submerged arc welding equipment. The OPC flux recovery units have a robust, compact design – easy to fit and easy to use. They can be fitted equally well to A2 and A6 equipment, both stationary or travelling. The OPC Basic recovery unit works on the ejector principle using compressed air.

Like the OPC Basic, the OPC Super recovery unit has been developed for use in a demanding working environment and on heavy-duty jobs. The OPC Super, with its stronger ejector and cyclone, produces higher suction height than the Basic. The OPC Super can also be used with pre-heated flux, as it is heat enforced.

There are three filter types for cleaning used air. A filter bag is used for A2 tractors and light-duty welding applications. A cyclone filter with a filter bag is a solution for most A2/A6 subarc welding. The Tedak filter is for heavy-duty and continuous welding applications.

To upgrade this system to a system for heavy continuous welding, add the FFS flux-feed system, and create the FFRS Basic & Super Flux system. For more information, see the leaflet entitled "FFRS – Basic & Super".

Technical data

OPC recovery unit Basic

Air-flow capacity at working pressure 0.6 MPa: 250 lit/min

Max suction height at working pressure 0.6 MPa: 0.8 m

OPC recovery unit Super

Air-flow capacity at working pressure 0.6 MPa: 580 lit/min

Max suction height at working pressure 0.6 MPa: 1.4 m

Ordering information

OPC Basic	0148 140 880
Air pressure hose 3/8", max 50 meters	0190 343 104
OPC Basic with cyclone filter	0802 415 882
OPC Basic with Tedak filter	0802 415 883
OPC Super with cyclone filter	0802 415 892
OPC Super with Tedak filter	0802 415 893
Air pressure hose 1/2", max 50 meters	0190 343 106
Filter tube diam. 63 mm, max 12 meters	0193 125 003



FFRS Basic & Super flux equipment

The FFRS system is designed for continuous, high-capacity welding operations. It is ideal for long runs and mass production. The system is built on two different modules: the OPC Basic and Super, which are based on the ejector principle. The Basic type is for normal welding operation. The Super is used with increased flux bead and heat conditions.

FFRS – Basic & Super

These are recirculated systems for continuous Submerged Arc Welding. FFRS Basic/Super are complete equipment combining the effective recovery of flux with OPC Basic/Super systems and flux feed to the flux hopper with the well-known flux tank TPC 75. Added to ordering data is inlet pipe type, straight or bent, for easy connection to standard delivered aluminium hopper.

The system FFRS Basic and Super are built up from variants of OPC Basic/Super and Flux feed system FFS. The FFS comprises of a flux tank TPC with different inlets for the 6 and 10-litre flux hopper.

The system of FFS consists of:

Air flux feed tank TPC 75

Plastic hose 1" for flux, 30 meter

Inlet to flux hopper

Included in the package is an instruction of how to install inlet in hopper with drilling data.

Ordering information

FFS (straight inlet)	0806 697 887
FFS (bent inlet)	0806 697 886

Welding automation

Flux equipment



FFRS 1200 & 3000 flux equipment

The FFRS system is designed for continuous, high-capacity submerged arc welding operations. It is ideal for long runs and mass production. The FFRS 1200 & 3000 are based on an electric suction unit creating a vacuum, which is the alternative when extra high recovery force is required. In confined areas, they are the ideal flux-handling equipment. On the FFRS 1200 and 3000, there is an electrically-powered recovery unit. The recovered flux is cleaned from dust and slag in the pre-separator and passed back to the pressure tank for re-use. On the FFRS 1200, the power is 1200 W and, on the FFRS 3000, it is 3.000 W. The FFRS 1200/3000 is a flux feed and recovery system for heavy production SAW stations or submerged arc welding in confined spaces.

Technical data

FFRS 1200

External dimensions, LxWxH, mm: 1053x450x2210

Weight, kg, without flux: 230

FFRS 3000

External dimensions, LxWxH, mm: 750x450x2210

Weight, kg, without flux: 400

FFRS 1200 suction unit P160

External dimensions, LxWxH, mm: 480x400x1160

Fuse, slow, A: 10

Mains supply, V/Hz: 110-230/50-60 (others on request)

Weight, kg: 19

FFRS 3000 suction unit for E-PAK 150

External dimensions, LxWxH, mm: 1200x690x2000

Fuse, slow, A: 16

Mains supply, V/Hz: 400/3-phase, 50 Hz (others on request)

Weight, kg: 194

Ordering information

FFRS 1200	0801 500 901
FFRS 3000	0801 500 921
Air pressure hose 1/2", max 50 m*)	0190 343 106
Suction hose D47/38, max 12 m*)	0379 016 001

Accessories FFRS

Bent inlet to flux hopper	0186 961 881
Straight inlet to flux hopper	0186 961 880
Extra hopper with inlet, see leaflet FFRS XA00104820	

*) length according to customer requirements

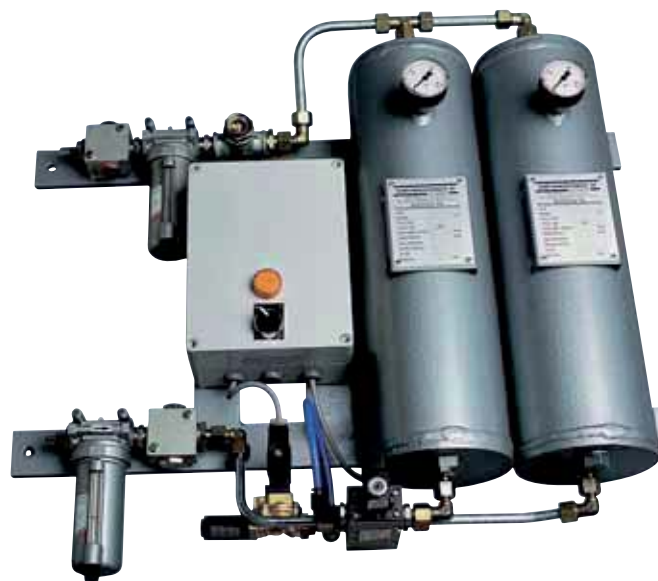

CRE 30/60 air-drying units

- Reduces the risk of hydrogen cracking
- Built-in monitor – warns if the pre-set humidity is exceeded
- Reduces condensation – less corrosion and malfunction

The A6 CRE 30/60 air-drying units are designed for use with the ESAB flux handling system. The air-drying units work on the adsorption principle and is reactivated cold.

Most industries use compressed air as an energy source for many processes. For most of them, humidity is of no importance. The welding industry uses compressed air to transport flux for submerged arc welding. The necessity to keep these consumables dry is well known. The need to keep the humidity in the air at a low level is of the same importance as all the other precautions that are taken in a weld shop to limit the risk of hydrogen cracking.

The CRE 30/60 are air dryers for compressed air. It connects to the normal air distribution system at a plant. The capacity is sufficient to handle a delivery/recovery system for SAW. Thirty normal cubic metres per hour is the capacity at rated input for CRE 30. For CRE 60 the capacity is sixty normal cubic metres per hour.

The CRE 30/60 reduces the condensation of water in pneumatic systems and thereby reduces corrosion and malfunction.

Another advantage is the built-in monitor that emits a warning if the pre-set dewpoint of the air is exceeded.

Ordering information

CRE 30 air-drying unit	0443 570 880
CRE 60 air-drying unit	0443 570 881
Desiccant type 512, 10 kg	0443 570 017
Oil filter	0443 570 018
Dust filter	0443 570 019

Welding automation

Column and boom



CaB 300/460 S

CaB 300 S

The CaB 300 S (standard) column and boom can reach over distances of 3 to 5 m both vertically and horizontally. The 180° column rotation facility provides a total action radius. The 4x4 size is capable of 150 kg load at the end of the boom. The A2 and A6 welding systems are easily combined with the CaB 300 S.

CaB 460 S

The CaB 460 S (standard) column and boom can reach over distances of 5 to 7 m both vertically and horizontally. The 180° column rotation facility provides a total action radius. The 6x4 size is capable of 350 kg load at the end of the rack and pinion driven boom. The A2 and A6 systems are easily combined with the CaB 460 S.

Station solution

Conventional column and boom with a movable boom and the welding head mounted at the end of the boom.



CaB 300/460/600 M

A modular range of column and booms, available in three load sizes. The modular system gives possibilities to configure a range of different welding station solutions that can fulfill most common welding applications.

Due to modularity and the fixed configuration possibilities the lead times for delivery can be kept at a minimum.

Station solution

Conventional column and boom with a movable boom and the welding head mounted at the end of the boom. Cable chains are included



Welding automation

Column and boom



CaB 300/460/600 C

A customized range of welding column and booms are available for different customer requirements and applications, with loading capacities and working strokes for utmost accessibility to the welding joints.

Based on the modular CaB range, solutions to meet the most demanding request can be achieved. Welding methods as TIG, plasma welding and SAW cladding as well as Narrow Gap can be chosen on customized stations.

We can offer four basic stations with numerous alternatives.

Station solution 1 is a conventional column and boom with a movable boom and the welding head mounted at the end of the boom.



Station solution 2 is a conventional column and boom, with a movable boom and one welding head mounted at the end, combined with a boom-carriage-mounted welding head. (Not CaB 300).



Station solution 3 side-boom manipulator with one or two welding heads. This welding station with 5-axes movement is the basic unit for welding girders and profiles and for joining plates and sections.



Station solution 4 is a side-boom manipulator with a double track boom. The welding heads are placed on each side of the boom. The boom carriages can be individually controlled by the joint tracking systems, on separate tracks. Positioning from the rail carriage helps to create a highly-efficient welding station for the transversal, double fillet welding of stiffeners, for example.



Welding automation

Column and boom



Telbo™ 9500

Telbo™ a giant innovative step towards highly productive automatic welding. Saving valuable workshop space by means of the unique 3-section telescope-like retraction of the boom and securing the safety of operator.

Outstanding 12 m reach-out with boom end loading capacity of heavy 500 kg with capacity to ensure superior productivity and quality of weld.

Telbo™ is ideal for internal /external circumferential welding of windtower applications.

Flexible production is the lodestar, no matter if mixed sizes and plate thicknesses are to be welded – productive results are obvious.

Loaded with 1000 kg Flux BigBag and 1000 kg Wire EcoCoils, welding is continuously performed and costly dwell times are minimized.

Features:

- PLC Control system for synchronized boom motion
- Automatic "Wind Back" of wire during boom retraction
- Telescopic wire guides
- Remote controlled flux nozzle
- Remote controlled height adjustment of joint tracking sensor
- Saving in Factory-floor foot print
- Increased workshop safety
- Enables flexible production
- Big Pack" handling concepts
- Camera supervision system (option)

Applications:

- Power generation, especially wind tower manufacturing lines
- Pipeline, pipe mill contractors
- General fabrication (small workshops with limited space)

Effective work range, m	9.5
Max reach out, m	12.5 *)
Max load at boom end, kg	500
Welding process	SAW
Welding heads	A6 SAW, Single/Tandem and Tandem/Twin
Control system	PLC / GMH
Operator seat	yes

*) Measured from column centre

Ordering information

For ordering information, please contact your nearest ESAB representative.

Welding automation

Column and boom



CaB 2200

- The Column & Boom CaB 2200 is purposely designed for light duty.
- A smooth 360-degree lockable rotation.
- Linear guidings on column and boom for smooth movement which makes it ideal for the MIG, TIG and SAW welding processes.
- Cable chain on column and boom.
- Movable carriage or fixed stand
- IP 55 pendant control station using low voltage on the generous 10 metre cable.
- A standard safety feature including anti-fall device and limit switches for all motions.
- Pay load of 70 kg.

CaB 2200

Power Supply, V	230/380/400/440
Frequency	50/60Hz-3ph
Vertical speed, mm/min	600
Boom Speed, mm/min	0-2050
Electrical Panel	IP 55
Rotation	Manual
Boom height max (a), mm	2500
Boom height min (a), mm	450
Boom height max (b), mm	2700
Boom extension max (c), mm	2500
Boom extension min (c), mm	490
Boom extension max (d), mm	2500
Boom extension min (d), mm	490
Wheel centre distance (e), mm	1600
Axle centre distance (f), mm	1500
Height of column (g), mm	3200

Ordering information

CaB 2200, manual carriage	0370 250 600
CaB 2200, fixed stand	0370 250 605



CaB 44, 55, 66 and 77

- The Column & Boom CaB 44, 55, 66 and 77 is purposely designed and robustly built to with-stand the rugged environment in the welding industry.
- A smooth 360-degree lockable rotation.
- All vertical and horizontal guidings are precisely machined for smooth movement.
- Solid state inverter for variable speed of horizontal travel and travel carriage.
- Worm gearbox for vertical travel via AC motor complete with brake for added safety.
- High tensile roller chain used for vertical travel with the addition of a counter balance system with the column that provides smooth effortless travel.
- IP 55 pendant control station using low voltage on the generous 10 metre cable.
- A standard safety feature including anti-fall device and limit switches for all motions.
- Pay load of 420 kg.

CaB 44 CaB 55 CaB 66 CaB 77

Overall height, mm	5425	6425	7425	8425
Boom length, mm	5700	6700	7700	8700
Vertical under boom (min), mm	1000	1000	1000	1000
Vertical under boom (max), mm	4000	5000	6000	7000
Boom range horizontal, mm	4000	5000	6000	7000
Rail G-G, mm	2000	2000	2500	3000
Vertical speed, mm/min	1250/1500 (50/60 Hz)			
Boom speed, mm/min	165/1650 (50/60 Hz)			
Travel Speed, mm/min	333/3335 (5~50Hz)			
Electrical	IP55			
Power Supply	380/400/415V-50Hz/3ph			
Power Supply	440/460/480V-60Hz/3ph			
Control Voltage, V AC	24			
Slewing	Manual			

Ordering information

CaB 44, motorised carriage	0370 250 601
CaB 55, motorised carriage	0370 250 602
CaB 66, motorised carriage	0370 250 603
CaB 77, motorised carriage	0370 250 604
CaB 44, fixed stand	0370 250 606
CaB 55, fixed stand	0370 250 607
CaB 66, fixed stand	0370 250 608
CaB 77, fixed stand	0370 250 609

Welding automation

Handling equipment



Roller beds

Roller beds are designed to enable large round items to be welded and handled during rotation welding for example. ESAB offers a large range of roller beds of different models and load possibilities. The range partly consists of conventional roller beds, where the operator manually and mechanically sets the distance between the rollers to different diameters – and partly self-adjusting roller beds, where the rollers automatically adjust themselves to the diameter of the workpiece. All roller beds are designed to be easily combined with ESAB A2/A6 program and can be controlled via a remote control unit or from the process controller PEK.

CD 5-120 and CI 5-120, conventional roller beds with rail bogie. Max loading capacity from 2.5 – 60 tons/section.

CD-30/60/100/120-DB and CI-30&0/100/120-IB, conventional roller beds with rail bogie. Max loading capacity from 15 – 60 tons/section.

FIR 35, 75 and 100. These units are part of a growing line and used especially in wind tower production. Max loading capacity 35, 75 or 100 tons.

FIT 30, 60 and 100, conventional idler roller beds with built-in hydraulic height adjustment. These units are part of a growing line and used especially in wind tower production. Max loading capacity 15, 30 or 50 tons.

FUB 30, complete unit for fit-up of section. One set of FUB consist of one power and one idler roller bed 30T. four independently adjusted rollers to align the two sections with each other. Max loading capacity 30 tons.

SD 5-100 and SI 5-100, self-aligning roller beds. Motorised and idler rail bogie versions. Max loading capacity 2.5 – 50 tons/section.

SD 5-100 DB and SI 5-100 IB, self-aligning roller beds. Motorised and idler rail bogie versions. Max loading capacity 2.5 – 50 tons/section.

Suitable application areas:

- Wind tower fabrication
- Offshore and shipyards
- Pressure vessels
- Pipelines

Versatile accessories

A wide range of accessories is available for ESAB's roller beds, which additionally improve workpiece handling during welding.

For more information, please contact your nearest ESAB representative.

Welding automation

Handling equipment



Positioners

Welding times can be drastically reduced by placing the workpiece on a positioner when welding. Up to 25 – 30 % higher welding speed can be achieved if the joint is welded lying down instead of vertically. The optimum welding position can always be obtained with ESAB's positioners.

Welding in the optimum position improves the welding quality as welding work becomes considerably easier for the welder to carry out in a safer way. The arc time factor also increases when welding in the positioner, especially when working on large, heavy workpieces. The changes in position of the workpiece is reduced to a minimum in comparison to using a spindle guide or other lifting tool, which often means unproductive waiting times.

ESAB has a wide program range of positioners for welding and these can also be used for installation work. During automated welding, a positioner is often a part of the total application and all the models are fully designed to be combined with ESAB's automation program, which means that they can be controlled remotely or connected by the application's process controller PEK.

Depending on the size, weight and complexity of the workpiece and position angle requirements, the following ESAB positioners are available:

RT 250 – RT 500

Two axis positioners for rotating and tilting lightweight workpieces. Maximum loading capacity from 250 to 500 kg.

RT 1 – RT 35

Two axis positioners for rotating and tilting workpieces. Maximum loading capacity from 1000-35000 kg.

The positioners of the RT-series have 2 axis; height and rotation, which give a perfect ergonomic working position.

All the positioners come with a low voltage (24V) remote control for all functions. For daily work these positioners offer perfect solutions with optimized motor and gear drive sizes.

TAP 1T and TAP 3T

Three axis positioners for lifting, rotating and tilting demanding workpieces. The positioners of the TAP-series have 3 axis; height, tilting angle and rotation. Thus 3-axis operation guarantees the ideal ergonomic working position. Height, angle and speed are continuously adjustable.

Suitable application areas:

- Pipe shops
- Vessels
- Cladding of dish ends
- Fuel tanks

Versatile accessories

A wide range of accessories is available for ESAB's positioners, which additionally improve workpiece handling during welding.

For more information, please contact your nearest ESAB representative.

Welding automation

Engineering, Arc welding



Welding solutions for Pipemills

ESAB is a complete, reliable partner for pipemill welding. Not only do we have in-depth experience of demanding multi-wire submerged-arc welding. We also have a comprehensive range of products for this type of production.

Flexible, reliable welding equipment

We have a wide range of products developed in house for various multi-wire SAW applications which are particularly suitable for pipe welding. The range includes AC-DC power sources in the Pipemill Edition, controls for multi-wire processes including documentation, as well as columns and booms with a wide variety of welding heads.

Precise, high-speed longitudinal welding

Our concept for longitudinal submerged-arc welding is suitable for pipes in a normal diameter range of 20-64", a normal wall thickness of 6 to 40 mm and a length of up to 18 m.

Internal and external welding

For internal welding we have designed pre-stressed booms as well as welding heads for up to four wires. During internal welding, front-mounted laser sensor guides the welding head via the cross-slide. Video camera observation of accurate guiding and the welding process is standard.

The external welding station is based on a column and boom solution with a very stable cross-slide to adapt to different pipe diameters. The actual welding head, with its up to five-wire feed systems mounted on a so-called "rainbow fixture", is based on the ESAB A6S-Arc Master System which has been tested more than 10.000 times.

Return current systems (Grounding)

High current circuits have to be closed back to the power source by efficient systems at constantly moving pipes. Flexible steel brushes in two rows in front and behind the welding process are pressed with defined force from outside to the pipe to catch the current with a minimum of Voltage loss and to surely avoid any arc blow effect, which would disturb the weld process.



Problem-free flux and wire feed systems

We offer the smooth feeding of wire in different diameters and the equally straightforward supply of new and re-used flux. The constant and reliable wire feed is secured by high torque wire feed motors and enclosed double wire straightening mounted in 90 degrees to each other.

The correct combination of compressed air, flux feeding, easy replenishment of new flux via the Big/Bag system, a vacuum unit, a reliable magnetic separator and continuous recovery helps to create welding stations with less downtime, high-quality welds and, last but not least, a cleaner working environment.

Spiral pipe welding

Many end users require spiral-welded pipes for different purposes, such as water pipes. Normally, the wall thickness is limited to 25 mm, but the diameter range can be up to roughly 2.5 m. As in longitudinal pipe welding solutions, an internal welding head mounted on a long boom and an outside head mounted on a column and boom are used for offline spiral pipe welding. However, this is the only similarity.

First of all, internal and external welding is performed at one and the same station. Internal welding starts first and, after half a turn, external welding then begins – internally with two or in some cases three wires and externally with one or three wires in the welding process, depending on the diameter and wall thickness of the pipe.

Ordering information

For more information, please contact your nearest ESAB representative.

Welding automation

Engineering



Beam welding

ESAB has more than 30 years' experience in the field of beam and profile welding. ESAB's beam and profile machines are equipped with the well-known and well-proven ESAB A6 system welding equipment.

ESAB offers you a complete and effective way of welding beams and profiles. Whether you weld I-, T- or L-beams, wide flange beams, columns, tapered beams or non-symmetrical beams, ESAB has the know-how and the welding equipment to match your efficiency, quality, precision, versatility, productivity and overall welding economy requirements.

The machines are of two types: IT-machines, where the beams are welded with the web unit in the vertical position, and I-machines, where the beams are produced in the horizontal position.

The main advantage of both machine types, apart from their high production capacity, is that the welding operation takes place when the flange and the web are pressed together under pressure in order completely to eliminate the gap between the surfaces. This ensures perfect weld quality.

The IT-machines have a built-in straightening device which compensates for the pull-back of the flanges (see picture). ESAB's beam-welding machine program gives you the opportunity to choose the right type of equipment for your particular type of production.

Total range of beam sizes that can be welded:

Machine type	Web	Flange
IT-258	200-2500 mm	100-800 mm
IT-158	200-1500 mm	100-800 mm

Ordering information

For more information please contact your nearest ESAB representative

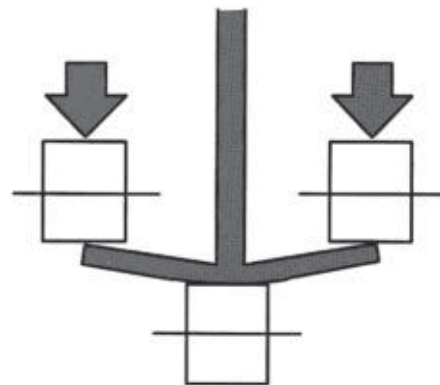

Straightening principle

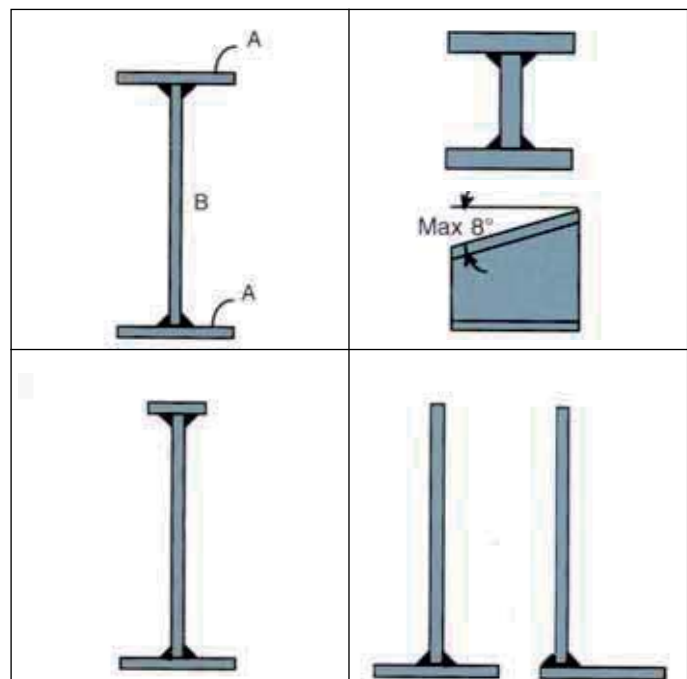

Examples of beams that can be welded

Welding automation

Friction Stir welding



ESAB Friction Stir Welding

ESAB has extended its product programme to include machines for the Friction Stir Welding method (FSW). This method has been developed and patented by TWI in the UK.

The FSW method is based on the principle of obtaining sufficiently high temperatures to forge two aluminium components, using a rotating tool that moves along the joint.

Using the FSW method, aluminium components are joined together without increasing the temperature above melting point.

The Friction Stir Welding of aluminium has been shown to produce joints with high-strength values and without inclusions and impurities.

Bending tests and tensile tests have been conducted with superb results. The fatigue properties are outstanding compared with other welding methods.

Furthermore, the joint is almost free from stress and has a perfect root surface when welded from one side. This results in a minimum of supplementary work.

Friction Stir Welding is ideal for joining straight profiles and flat plates with a thickness of 1.2-25 mm. When welding materials with a thickness of more than 15 mm, the welding is done from both sides. The maximum thickness is around 60 mm at 100% penetration.

Suitable application areas:

- Shipbuilding
- Offshore platforms
- Aerospace industry
- Railway wagons, trams, underground train carriages
- Automotive industry
- Production of electric motors
- Defence industry
- Cooling elements
- Basically all aluminium, copper and magnesium alloys can be friction stir welded with high quality and speed.



ESAB LEGIO™

The ESAB LEGIO™ concept combines the latest technology with proven quality. The modular system makes it possible to assemble welding stations to suit the most varied friction stir welding applications.

The LEGIO™ system consists of five basic designs in a series of seven sizes, covering a welding depth of 1.2 mm to 60 mm. These basic types can be supplemented with different types of equipment to suit the most varied production needs and give maximum flexibility to any production line.

The S- and the U-models are designed to be easily integrated with larger fixtures, rotary units and exchangeable clamping systems.

For the production of smaller workpieces, the UT- and the ST-model are the most suitable. They have tables prepared with a hole pattern, where fixtures can be attached.

ESAB SuperStir™

The ESAB SuperStir™ programme includes a variety of machines developed from a standardized ESAB SuperStir™ base unit and with working ranges of 0.5 x 1.5 m up to 10x20 m within the same concept.

The programme also include customized models of different designs to meet our customers specifications in their different production areas.

These different designs are today used worldwide in R&D centers, in joining of extrusions to panels, in production of pressure vessels as well as small parts for the automotive and electronic industries etc.

Welding automation

Friction Stir welding



Rosio™ Friction Stir Welding Robot

Friction Stir Welding Robot for welding of challenging joints
The ESAB Friction Stir Welding robot system enables flexible joining of complex structures, preferably in Aluminium. The ability to perform welds in an arbitrary direction of a 3-dimensional workspace increases the possibilities of usage for new challenging FSW applications.

The FSW method's benefits:

- Reliable and uniform high weld quality
- Unbeatable strength
- High productivity
- Low distortion and shrinkage
- Minimum of supplementary work
- Low energy consumption
- Environment friendly



Flash butt welding

ESAB manufacture a complete series of flash butt welding machines for different welding objects with a welding area of 500 mm² up to 30,000 mm².
The flash butt welding technique is especially convenient and profitable for precision and mass production work as it permits a high level of mechanization and automation of the manufacturing process.

ESAB's resistance welding program

Chain-making installations, type Carousel
Size 5 – 10, Ø 18 – 173 mm

Fully automated chain-making plant type ZAC

ZAC 554 Ø 18–34 mm
ZAC 42M Ø 18–42 mm

Chain-welding installation, type Rocat

WT 18–26 Ø 18–26 mm
WT 22–36 Ø 22–36 mm

Fully automatic link-bending plant, type YLNB

YLNB 451 Ø 14–26 mm
YLNB 552 Ø 22–36 mm

Flash butt welding machines, type SVU-K

Welding areas 1,400 – 10,000 mm²
Th figures are based on an upsetting force of 5 kp/mm²

Resistance heaters, type ZSM

Ø 14 – 173 mm depending on size of machine

Chain-bending machines, type ZKBH

Ø 17 – 173 mm, depending on size of machine

Rail-welding machine, type ZFR

ZFSC 10 Welding areas 12,000 mm²
ZFR 10 B Welding areas 10,000 mm²
ZFR 11 GC Welding areas 12,000 mm²

Flash butt welding machine for tubes, type SVU

SVU 7884-H Welding areas 2,300 mm²
SVU 8884-H Welding areas 3,600 mm²

Flash butt welding machines for repair anode studs in the aluminium industry

SVU 9883-S Ø 140 mm
ZF 12 AA Ø 160 mm

A

A2 4WD Wire feeder, feed roller single solid wire	91
A2 Multitrac with A2 process controller PEI	82
A2 Multitrac with A2/A6 process controller PEK	82
A2 process controller PEI	95
A2 S GMAW Mini Master	86
A2 S Mini Master	86
A2 Tripletrac	83
A2/A6 Beam-travelling carriage	92
A21 PRB	64
A21 PRC	65
A21 PRD 100	65
A21 PRD 160	66
A21 PRH	66
A22 POC	67
A25	68
A25 components and accessories	71
A2-A6 Process Controller PEK	95
A6 Mastertrac	84
A6 S Arc Master	87
A6 S Compact	88
A6 S Tandem Master	87
A6 synergic cold wire	94
A6-DK	84
Adapter M6/M10	90
AGW1 and AGW Single-side & Double-side tank welder ...	85
Angular support	72

Aristo [®] Feed 3004/4804, U6/U8 ₂	33
Aristo [®] MechControl 2 and 4	74
Aristo [®] MechTig 3000i	75
Aristo [®] MechTig 4000iw	75
Aristo [®] MechTig C2002i	74
Aristo [®] Mig 5000i	29
Aristo [®] Mig C3000i, U6	24
Aristo [®] Mig U4000i/U5000i	29
Aristo [®] RoboFeed 3004w	33
Aristo [®] Tig 4000i	12
Aristo [®] U8 ₂ /W8 ₂	36
Aristo [®] YardFeed 2000, U6 Origo™ YardFeed MA23	35
AT1	49
AT1 CAN	48
AT1 CoarseFine	49
AT1 CoarseFine CAN	48

B

Balancing block	72
Beam welding	105

C

CaB 2200	101
CaB 300/460 S	98
CaB 300/460/600 C	99
CaB 300/460/600 M	98
CaB 44, 55, 66 and 77	101
Caddy [®] Arc 151i, A31	3
Caddy [®] Arc 151i/201i, A33	3
Caddy [®] Arc 251i, A32/A34	4

Caddy [®] Mig C160i	22
Caddy [®] Mig C200i	23
Caddy [®] Tig 1500i/2200i, TA33	10
Caddy [®] Tig 1500i/2200i, TA34	10
Caddy [®] Tig 2200i AC/DC	13
Collets and cartridges	70
Contact jaws D35	90
Contact jaws heavy twin	90
Contact nozzles wire size	90
Control panel functions	52, 53

CoolMidi 1000	54
CoolMidi 1800	55
CoolMini	54
Counterbalance device/mast	37
CRE 30/60 air-drying units	97

E

ESP 150	60
---------------	----

F

Feed roller grooved	91
Feed roller single wire size	90
Feed roller twin wire size.....	91
FeedSelector	57
FFRS 1200 & 3000 flux equipment	97
FFRS Basic & Super flux equipment	96
Flash butt welding	107
Frametrac™	79
Friction Stir Welding	106
FS 002	49

G

Gantrac	93
---------------	----

I

Interconnection cables	38
Introduction Orbital TIG	64

K

KHM 190 HS - petrol	6
KHM 190 YS - diesel	6
KHM 351 YS	7
KHM 405 YS	7
KHM 525 PS	8
KHM 595 PS	8
Knurled feed roller single wire	91

L

LAF 631, 1001, 1251 and 1601	89
LEGIO™	106
Lifting eye	37

M

M1	49
M1 10Prog CAN	49
MechTrac 1730, 2100, 2500 and 3000	92
MEI 10 wire feed unit	73
MEI 21 wire feed unit	73
Miggytrac 1001	80
Miggytrac 2000	81
Miggytrac 3000	81
MMA welding cables	9
MobileFeed 200AVS / 300AVS	34
MTA1 CAN	48
MTW 600 MIG Torch, Contact nozzle M8	91
Multi Voltage units	57
MXH™ 300/400w PP	45
MXL™ Torches	42

N

Narrow gap head for PRD	72
-------------------------------	----

O

OCE-2 H	56
OCE-2 H cooling unit	94
OPC Basic & Super flux equipment	96
Origo™ Arc 250/300/400	5
Origo™ Arc 4001i, A22/A24	4
Origo™ Arc 410c/650c/810c	5
Origo™ Cut 36i	58
Origo™ Feed 3004/4804, MA23/MA24	32
Origo™ Feed 302/304/484, M11/M12	31
Origo™ Feed 304/484, M13 -19 pole	31
Origo™ Feed L302/L304	30
Origo™ FeedAirmatic, M10	30
Origo™ Mag C171/C201/C251	20
Origo™ Mig 3001i, A24 - Mig 3001i/3001iw	27
Origo™ Mig 320	25
Origo™ Mig 4001i, A24 - Mig 4001i/4001iw	27
Origo™ Mig 4002c/5002c/6502c	26
Origo™ Mig 402c/502c/652c	26
Origo™ Mig 410/510	25
Origo™ Mig C141/C151	20
Origo™ Mig C170 3ph/C200 3ph/C250 3ph	21
Origo™ Mig C280 PRO/C340 PRO	21
Origo™ Mig C3000i, MA23A	23
Origo™ Mig C420 PRO/C420w PRO	22
Origo™ Mig L405	24
Origo™ Tig 3000i AC/DC, TA24 AC/DC	13
Origo™ Tig 3001i, TA23	11
Origo™ Tig 3001i, TA24	11
Origo™ Tig 4300iw AC/DC, TA24 AC/DC	14
Origo™ YardFeed 200, M13y	34
Other equipment for MIG/MAG welding	39

P

PKB™ 250/400	45
Plasma gouging	61
POC 12-60 accessories	71
POC shafts and centering mandrels	71

Positioners	103
Positioning and joint tracking system	95

Pressure roller wire size	91
Pressure roller, single wire	90
Pressure roller, twin wire	91
PSF™ 315M	44
PSF™ Centrovac self-cooled	43
PSF™ Centrovac water-cooled	44
PSF™ self-cooled	42
PSF™ water-cooled	43
PT 26	61
PT 31XL	61
PT 37	62
PT 38	62

R

Railtrac 1000	76
Railtrac BV1000/BVR1000	78
Railtrac F1000	77
Railtrac FR1000	77
Railtrac FW1000/FW1000 L	77
Railtrac FWR1000	77
Railtrac Orbital W	80
Remote Adapter 12	50
Remote Adapter 23	50
Remote control Mecht 1 CAN	72
Remote-control MIG 2	50
Remote-control MMA 1	50
Remote-control MMA 2	50
Roller beds	102
Rosio™ Friction Stir Welding Robot	107

S

Slides	94
Standard racks for PRD 100	69
Standard racks for PRD 160	69
Strain relief for welding torch	37
SuperStir™	106

T

TAF 801 and 1251	88
Telbo™ 9500	100
TIG torches and components	18, 19
Tigaid 315 AC/DC	14
Torch guide kits	61
Tramtrac™ II	78
Transmitter NO2	50
Turning piece	37
TXH™ 120, 120V, 120F	15
TXH™ 150, 150V, 150F	15
TXH™ 200, 200V, 200F	16
TXH™ 250w, 250wF, 400w, 400w HD	16
TXH™ remote torches	17

W

Walltrac	93
Wear part kits	61
Wear parts A2/A6	90, 91
Wear parts for wire feeders	40, 41
Welding solutions for Pipemills	104
WeldPoint™	36
Wheel kit	37
Wire feed units	95

World leader in welding and cutting technology and systems.



ESAB operates at the forefront of welding and cutting technology. Over one hundred years of continuous improvement in products and processes enables us to meet the challenges of technological advance in every sector in which ESAB operates.

Quality and environment standards

Quality, the environment and safety are three key areas of focus. ESAB is one of few international companies to have obtained the ISO 14001 and OHSAS 18001 standards in Environmental,

Health & Safety Management Systems across all our global manufacturing facilities.

At ESAB, quality is an ongoing process that is at the heart of all our production processes and facilities worldwide. Multinational manufacturing, local representation and an international network of independent distributors brings the benefits of ESAB quality and unrivalled expertise in materials and processes within reach of all our customers, wherever they are located.

ESAB Sales and Support Offices worldwide

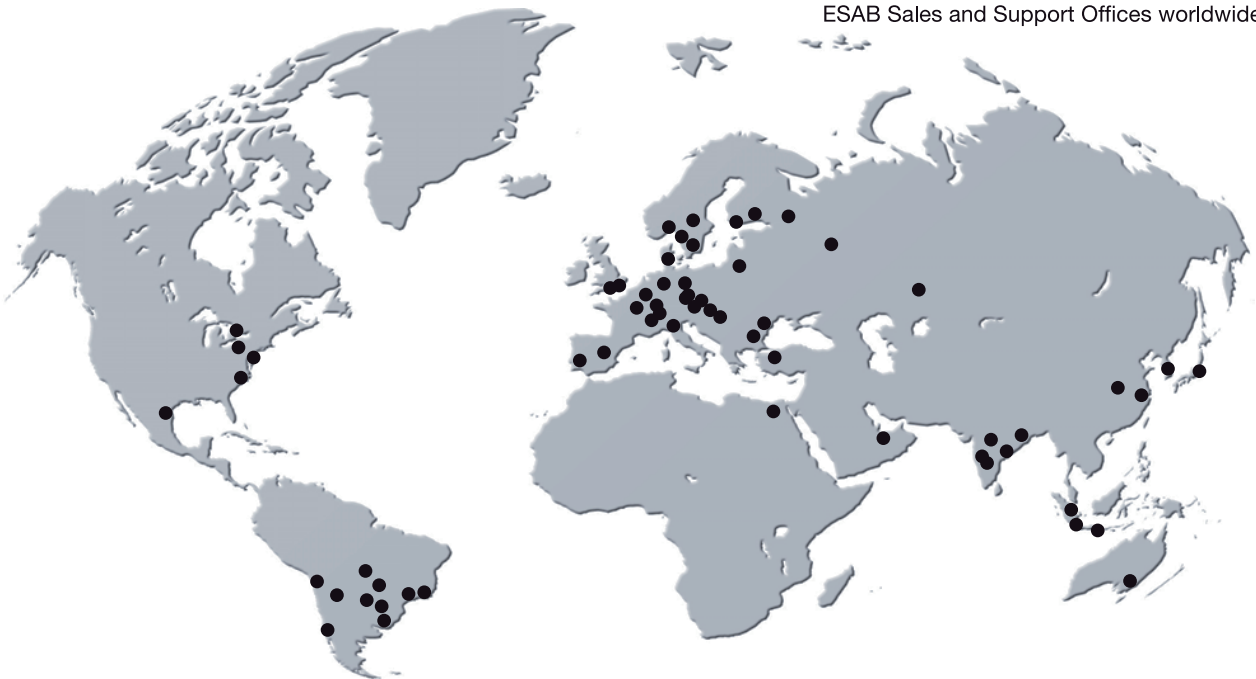

* Includes manufacturing facilities of ESAB North America. A wholly owned subsidiary of Anderson Group Inc.

XA00151420 ESAB reserves the right to alter specifications without prior notice.



ESAB AB
Box 8004, SE-402 77 Göteborg, SWEDEN
Phone: +46 31 50 90 00
E-mail: info@esab.se
www.esab.com

